



Whatever your idea. We deliver.

WASHBASINS AND SINKS.

Was auch immer Ihre Idee ist. Wir liefern. WASCH- UND SPÜLBECKEN

Quelle que soit votre idée. Nous la réalisons. VASQUES ET CUVES.



INFINITY. POWER.
IMAGINATION.

KITCHEN. BATHROOM. **KERROCK.**

Among all pieces of furniture, those in kitchen and bathroom are most often in use, so this is why we pay very special attention to them here at Kolpa. Functionality, robustness, ease to clean, sublime style and multiple design options are more than a good reason to choose a washbasin or a sink made from Kerrock.



Thought over.
To the last
detail.



UNENDLICHKEIT. KRAFT. PHANTASIE. KÜCHE. BAD. **KERROCK.**



Küche- und Badmöbel sind die meistgebrauchte Möbelstücke in Ihrem Haus, deshalb schenkt Kolpa diesem Bereich eine ganz besondere Aufmerksamkeit. Funktionalität, Robustheit, einfache Reinigung, hervorragendes Design und vielfache Gestaltungsmöglichkeiten sind mehr als gute Gründe, um ein Wasch- oder Spülbecken aus Kerrock zu wählen.





Durchdacht. Bis
ins letzte Detail.

Réfléchi. Jusqu'au
dernier détail.

INFINITÉ. PUISSANCE. IMAGINATION. CUISINE. SALLE DE BAINS. **KERROCK.**

Les meubles de cuisine et de salle de bains sont les meubles les plus utilisés dans une maison, c'est pourquoi Kolpa leur accorde une attention particulière. Fonctionnalité, résistance, nettoyage facile, ligne élégante et design sont autant de bonnes raisons de choisir un lavabo ou un évier Kerrock.

KERROCK GETS INTRODUCED. WITH EXPERIENCE.



PLEASURE OF THE TOUCH

Look of stone, pleasant and warm to the touch. Attractive and inviting surface structure.

Touch it and see how nice it feels.

MECHANICAL RESISTANCE, RESISTANCE TO CHEMICALS

Surface structure designed to limit the mechanical damage and so to maintain its like-new-appearance for long. Various food stains can easily be removed. Kerrock makes ravages of time invisible.

CLIMATIC AND HEAT RESISTANCE

Solid and remarkably homogenous this material expresses stability, robustness and prevents cracking. It is resistant to hot objects and flame-retardant. Insensitive to external and internal climatic conditions. Perfectly non-porous, so absolutely water and moisture resistant.



ANTIBACTERIAL AND HEALTH-FRIENDLY

In addition to the original Kerrock you can opt for an innovative material called Kerrock plus, featuring an antibacterial substance fully integrated in its overall structure. At the touch bacteria are immediately eradicated and their further development continuously prevented.



THE INFINITE
POWER
OF STYLE

DIE UNENDLICHE
KRAFT DES
DESIGNS

L'INFINI
POUVOIR DE LA
CONCEPTION



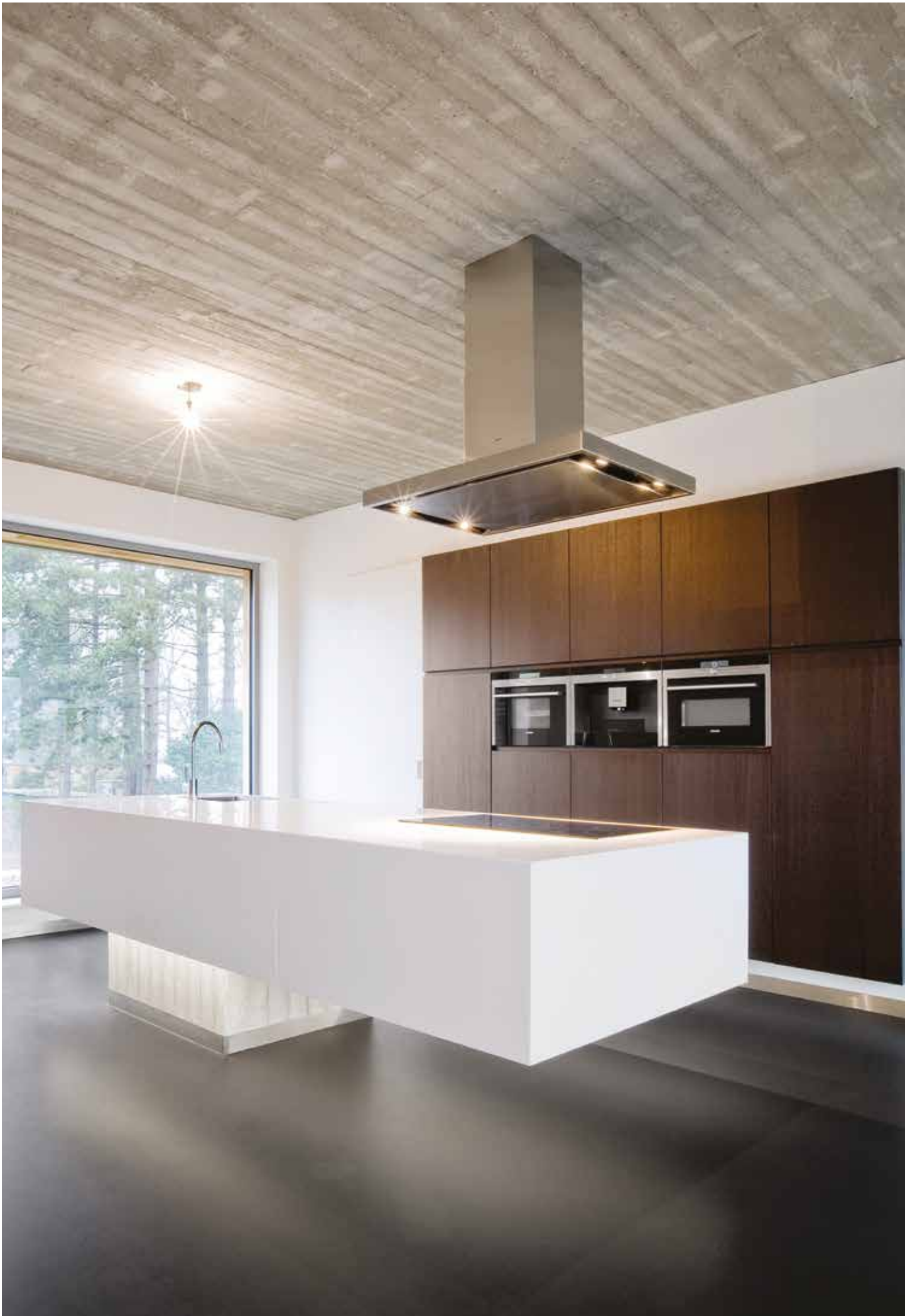



Versatile. **KERROCK.**

By **implementing Kerrock** you make the lines between the in- and the outdoor get blurred. With its organic design it melts with the environment, raising the overall harmony. Through its quite astonishing design options and a wide range of colours it can assume countless forms of occurrence. Kerrock. Truly versatile.

Vielseitig. **KERROCK.**

Durch den **Einsatz von Kerrock** verschwinden die Grenzen zwischen Innen und Außen. Sein organisches Design verschmilzt mit der Umgebung und steigert die Harmonie. Durch seine erstaunlich vielfältigen Gestaltungsmöglichkeiten und eine breite Palette von Farben kann es unzählige Formen annehmen. Kerrock. Wahrhaftig vielseitig.

Universel. **KERROCK.**

En **mettant en oeuvre du Kerrock**, nous brisons la limite entre l'espace extérieur et intérieur. Grâce à son design organique, il se mélange à l'environnement, il souligne l'harmonie naturelle. Grâce à son incroyable capacité conceptuelle et sa large gamme de couleurs, il peut prendre toutes les formes. Kerrock. Totalement universel.

On the building or inside it – Kerrock is there to impress!



KERROCK STELLT SICH VOR. MIT ERFAHRUNG.

FÜHLT SICH ANGENEHM AN

Sieht aus wie Stein, fühlt sich angenehm an und wirkt warm. Attraktive und ansprechende Oberflächenstruktur. Überzeugen Sie sich selbst, wie angenehm Kerrock auf Berührung ist.

MECHANISCHE FESTIGKEIT, BESTÄNDIGKEIT GEGEN CHEMIKALIEN

Die Oberflächenstruktur ist so entworfen, das mögliche mechanische Schäden begrenzt bleiben, so dass seine Optik wie neu erhalten bleibt. Verschiedene Lebensmittelflecken können ganz einfach entfernt werden. Kerrock trotz dem Zahn der Zeit.

KLIMA- UND HITZEBESTÄNDIGKEIT

Dieses massive und bemerkenswert homogene Material beeindruckt mit Stabilität, Robustheit und verhindert Rissbildung. Beständig gegen heiße Gegenstände und selbstauslöschend. Unempfindlich gegenüber äußeren und inneren klimatischen Bedingungen. Völlig porenfrei und damit absolut wasser- und feuchtigkeitsfest.

ANTIBAKTERIELL UND GESUNDHEITSFREUNDLICH

Zusätzlich zu Original-Kerrock können Sie ein innovatives Material namens Kerrock Plus mit einer, in die Gesamtstruktur völlig integrierten, antibakteriellen Substanz wählen. Beim Kontakt werden Bakterien sofort beseitigt und ihre Entwicklung wird kontinuierlich verhindert.



KERROCK SE PRÉSENTE. TENTEZ L'EXPÉRIENCE.

AGRÉABLE AU TOUCHER

Bien qu'il rappelle la pierre par son aspect, il est agréable et chaleureux au toucher. Sa surface est attractive et plaisante. Une impression agréable se dégage à son toucher.

RÉSISTANT AUX CHOCS, RÉSISTANT AUX PRODUITS CHIMIQUES

Sa surface est résistante, elle permet de limiter les détériorations et de conserver longtemps un bel aspect lisse. Les aliments et les produits chimiques ne le tâchent pas. Les ravages du temps ne laissent pas de trace sur les produits Kerrock.

RÉSISTANCE CLIMATIQUE ET THERMIQUE

Solide et extrêmement homogène, ce matériau exprime la force et la robustesse et prévient la formation de fissurations. Il est résistant à la chaleur et ignifuge. Il est insensible aux conditions climatiques extérieures et intérieures. Sa non porosité rend sa surface complètement résistante à l'eau et aux effets de l'humidité.

ANTIBACTÉRIEN ET RESPECTUEUX DE LA SANTÉ

En plus du matériel Kerrock classique, nous vous proposons également un matériau innovant Kerrock Plus avec un agent antibactérien intégré dans sa structure globale. Au toucher, sa structure détruit les bactéries et empêche de manière continue leur développement.

*Ob Fassade oder Interieur – Kerrock ist da, um zu beeindrucken!
A l'extérieur d'un bâtiment comme à l'intérieur – Kerrock exalte !*





WASHBASINS

WASCHBECKEN / VASQUES



Bathroom. No longer limited to just a place of personal hygiene. Bathroom has become art. Functional art. And Kerrock the artist with experience.

Badezimmer. Schon lange nicht mehr nur für Körperpflege bestimmt. Das Bad hat sich zur Kunst entwickelt. Funktionale Kunst. Und Kerrock zum Künstler mit Erfahrung.

La salle de bains. Elle ne se limite plus à être le lieu de l'hygiène corporelle. La salle de bains est devenue un art. Un art fonctionnel. Et Kerrock en est l'artiste expérimenté.

Actual dimensions may vary from stated ones (the plan). Die angegebenen Dimensionen können (vom Entwurf) abweichen. Les dimensions réelles peuvent différer (de celles du plan).



Formen, die Harmonie
im Raum schaffen.
Les formes qui dégagent
de l'harmonie dans
l'espace.

“ Shapes that create harmony in space.

Kerrock **washbasins** / Kerrock **Waschbecken** / Ke



● ● 1090, 5080,
5083, 9095

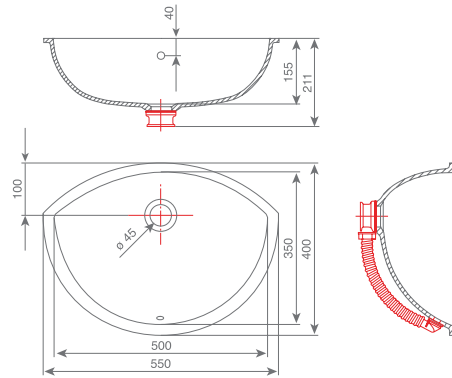

010 SILVIA

INTERIOR DIMENSIONS / INNENDIMENSIONEN / DIMENSIONS INTÉRIEURES

#length / Länge / longueur : 500 mm #width / Breite / largeur : 350 mm #depth/ Tiefe / profondeur : 155 mm #ø 45 mm



● ● 1090, 5080,
5083, 9095

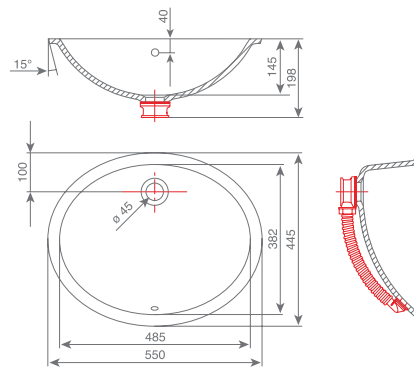

011 TINA

INTERIOR DIMENSIONS / INNENDIMENSIONEN / DIMENSIONS INTÉRIEURES

#length / Länge / longueur : 485 mm #width / Breite / largeur : 382 mm #depth/ Tiefe / profondeur : 145 mm #ø 45 mm



● ● 1090, 5080,
5083, 9095

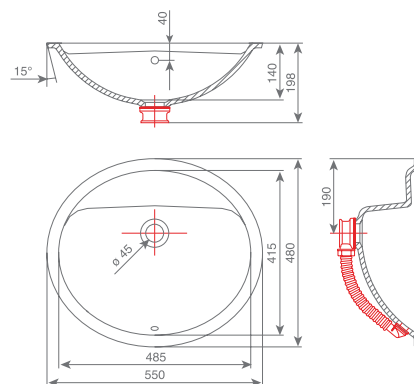

012 PETRA

INTERIOR DIMENSIONS / INNENDIMENSIONEN / DIMENSIONS INTÉRIEURES

#length / Länge / longueur : 485 mm #width / Breite / largeur : 415 mm #depth/ Tiefe / profondeur : 140 mm #ø 45 mm

● This washbasin is available in unicolours. / Dieses Waschbecken ist in Uni Colour Farben erhältlich. / Modèle disponible dans les coloris unis.

● This washbasin is available in all granite colours. / Dieses Waschbecken ist in Granitfarben erhältlich. / Modèle disponible dans toutes les nuances de granit



● ● 1090, 5080,
5083, 9095

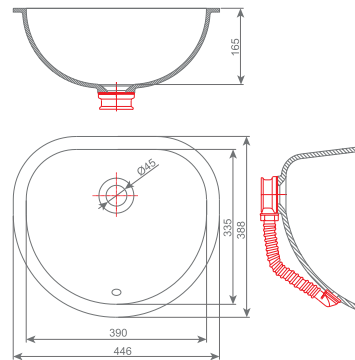

013 TRU

INTERIOR DIMENSIONS / INNENDIMENSIONEN / DIMENSIONS INTÉRIEURES

#length / Länge / longueur : 390 mm #width / Breite / largeur : 335 mm #depth/ Tiefe / profondeur : 165 mm #ø 45 mm



● ●

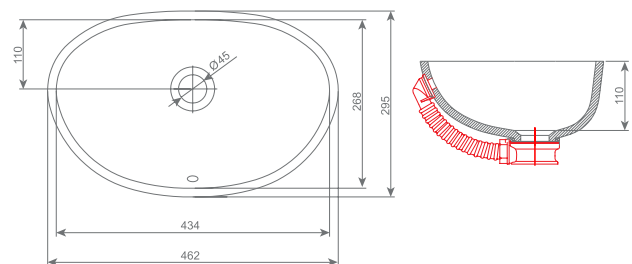

040 SARA

INTERIOR DIMENSIONS / INNENDIMENSIONEN / DIMENSIONS INTÉRIEURES

#length / Länge / longueur : 434 mm #width / Breite / largeur : 268 mm #depth/ Tiefe / profondeur : 110 mm #ø 45 mm



● ●

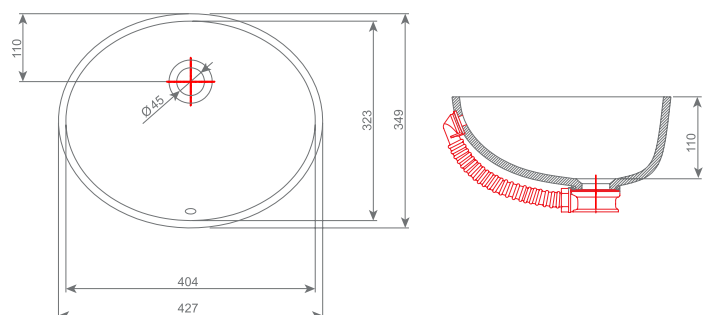

041 BLANCA

INTERIOR DIMENSIONS / INNENDIMENSIONEN / DIMENSIONS INTÉRIEURES

#length / Länge / longueur : 404 mm #width / Breite / largeur : 323 mm #depth/ Tiefe / profondeur : 110 mm #ø 45 mm

● 1090, 5080, 5083, 9095 | This washbasin is available in granite colours 1090, 5080, 5083 in 9095. / Dieses Waschbecken ist nur in Granitfarben 1090, 5080, 5083 und 9095 erhältlich. / Modèle disponible uniquement dans les nuances de granit suivantes 1090, 5080, 5083 et 9095.

Kerrock **washbasins** / Kerrock **Waschbecken** / Ke

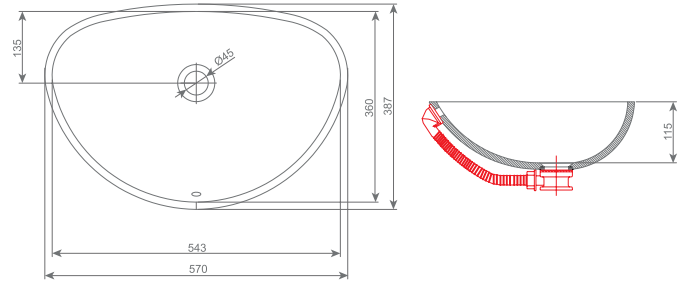

042 LANA

INTERIOR DIMENSIONS / INNENDIMENSIONEN / DIMENSIONS INTÉRIEURES

#length / Länge / longueur : 543 mm #width / Breite / largeur : 360 mm #depth/ Tiefe / profondeur : 115 mm #ø 45 mm

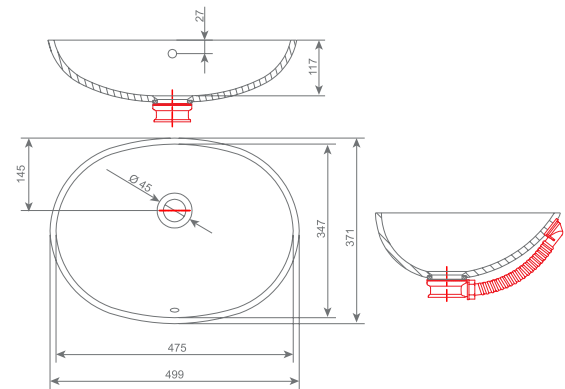

030 EVA

INTERIOR DIMENSIONS / INNENDIMENSIONEN / DIMENSIONS INTÉRIEURES

#length / Länge / longueur : 475 mm #width / Breite / largeur : 347 mm #depth/ Tiefe / profondeur : 117 mm #ø 45 mm

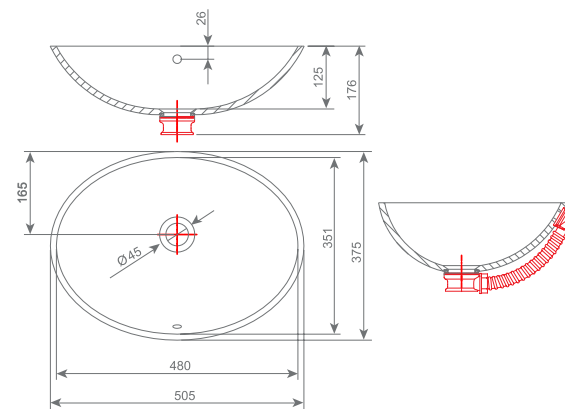

031 MAJA

INTERIOR DIMENSIONS / INNENDIMENSIONEN / DIMENSIONS INTÉRIEURES

#length / Länge / longueur : 480 mm #width / Breite / largeur : 351 mm #depth/ Tiefe / profondeur : 125 mm #ø 45 mm

● This washbasin is available in unicolours. / Dieses Waschbecken ist in Uni Colour Farben erhältlich. / Modèle disponible dans les coloris unis.

● This washbasin is available in all granite colours. / Dieses Waschbecken ist in Granitfarben erhältlich. / Modèle disponible dans toutes les nuances de granit

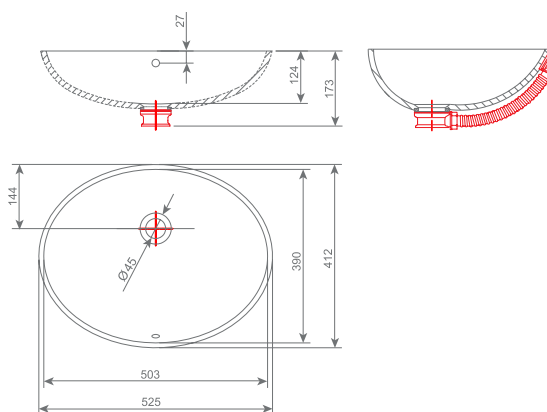

032 IVA

INTERIOR DIMENSIONS / INNENDIMENSIONEN / DIMENSIONS INTÉRIEURES

#length / Länge / longueur : 503 mm #width / Breite / largeur : 390 mm #depth/ Tiefe / profondeur : 124 mm #ø 45 mm

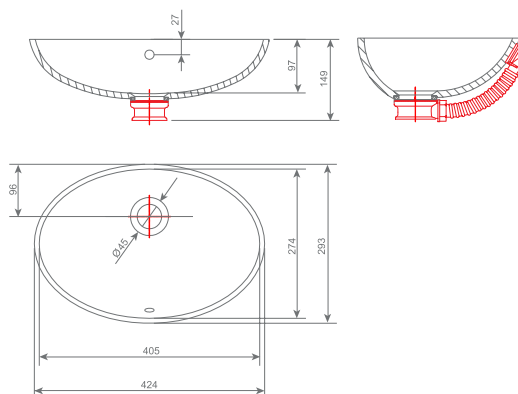

033 ANA

INTERIOR DIMENSIONS / INNENDIMENSIONEN / DIMENSIONS INTÉRIEURES

#length / Länge / longueur : 405 mm #width / Breite / largeur : 274 mm #depth/ Tiefe / profondeur : 97 mm #ø 45 mm

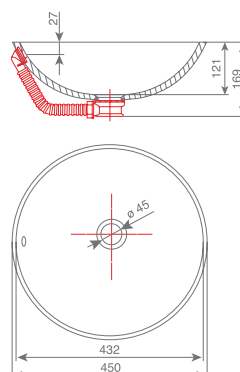

034 RONDO

INTERIOR DIMENSIONS / INNENDIMENSIONEN / DIMENSIONS INTÉRIEURES

#length / Länge / longueur : 432 mm #depth/ Tiefe / profondeur : 121 mm #ø 45 mm

1090, 5080, 5083, 9095 | This washbasin is available in granite colours 1090, 5080, 5083 in 9095. / Dieses Waschbecken ist nur in Granitfarben 1090, 5080, 5083 und 9095 erhältlich. / Modèle disponible uniquement dans les nuances de granit suivantes 1090, 5080, 5083 et 9095.

Kerrock **washbasins** / Kerrock **Waschbecken** / Ke

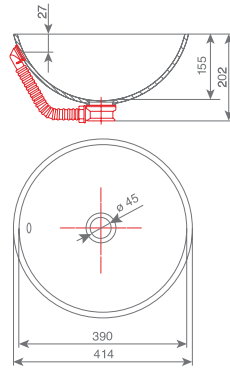

038 META

INTERIOR DIMENSIONS / INNENDIMENSIONEN / DIMENSIONS INTÉRIEURES

#length / Länge / longueur : 390 mm #depth/ Tiefe / profondeur : 155 mm #ø 45 mm

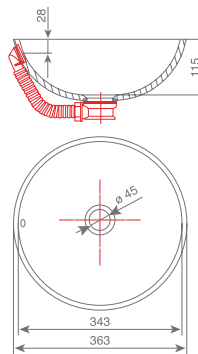

035 KERI

INTERIOR DIMENSIONS / INNENDIMENSIONEN / DIMENSIONS INTÉRIEURES

#length / Länge / longueur : 343 mm #depth/ Tiefe / profondeur : 115 mm #ø 45 mm

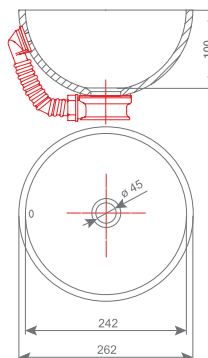

043 JANA

INTERIOR DIMENSIONS / INNENDIMENSIONEN / DIMENSIONS INTÉRIEURES

#length / Länge / longueur : 242 mm #depth/ Tiefe / profondeur : 100 mm #ø 45 mm

● This washbasin is available in unicolours. / Dieses Waschbecken ist in Uni Colour Farben erhältlich. / Modèle disponible dans les coloris unis.

● This washbasin is available in all granite colours. / Dieses Waschbecken ist in Granitfarben erhältlich. / Modèle disponible dans toutes les nuances de granit

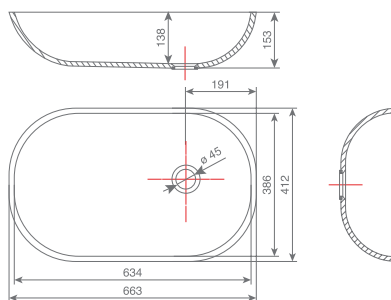

036 BARBI

INTERIOR DIMENSIONS / INNENDIMENSIONEN / DIMENSIONS INTÉRIEURES

#length / Länge / longueur : 634 mm #width / Breite / largeur : 386 mm #depth/ Tiefe / profondeur : 138 mm #ø 45 mm

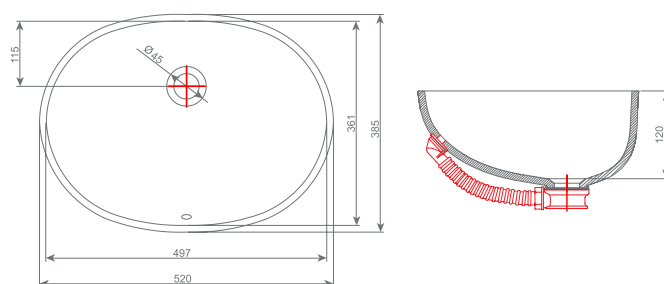

037 AJDA

INTERIOR DIMENSIONS / INNENDIMENSIONEN / DIMENSIONS INTÉRIEURES

#length / Länge / longueur : 497 mm #width / Breite / largeur : 361 mm #depth/ Tiefe / profondeur : 120 mm #ø 45 mm

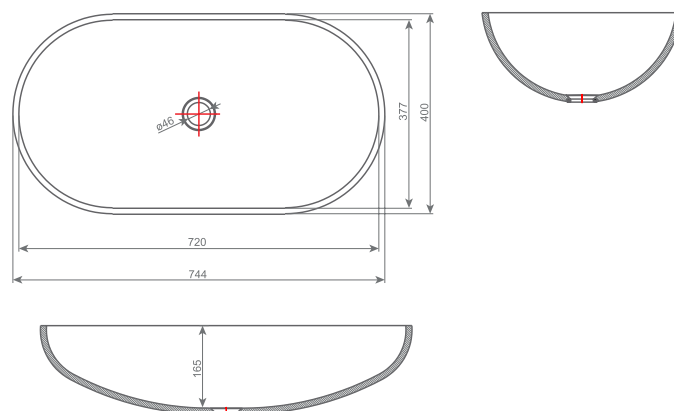

039 BEA

INTERIOR DIMENSIONS / INNENDIMENSIONEN / DIMENSIONS INTÉRIEURES

#length / Länge / longueur : 720 mm #width / Breite / largeur : 377 mm #depth/ Tiefe / profondeur : 165 mm #ø 45 mm

 1090, 5080, 5083, 9095 | This washbasin is available in granite colours 1090, 5080, 5083 in 9095. / Dieses Waschbecken ist nur in Granitfarben 1090, 5080, 5083 und 9095 erhältlich. / Modèle disponible uniquement dans les nuances de granit suivantes 1090, 5080, 5083 et 9095.

Kerrock **washbasins** / Kerrock **Waschbecken** / Ke

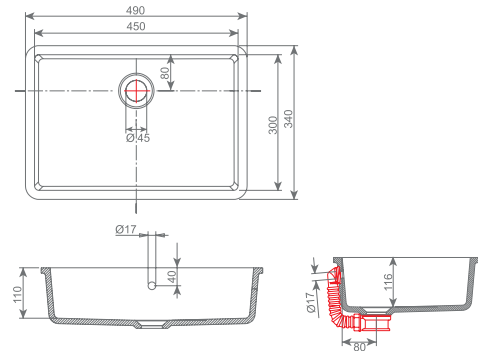

044 BRINA

INTERIOR DIMENSIONS / INNENDIMENSIONEN / DIMENSIONS INTÉRIEURES

#length / Länge / longueur : 450 mm #width / Breite / largeur : 300 mm #depth/ Tiefe / profondeur : 110 mm #ø 45 mm

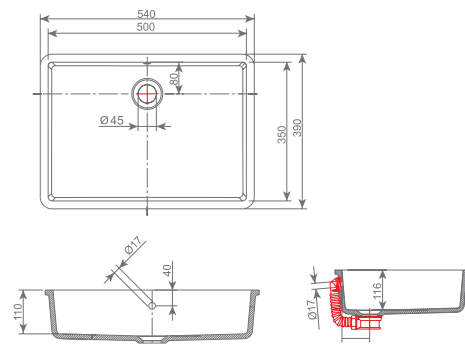

045 CHERI

INTERIOR DIMENSIONS / INNENDIMENSIONEN / DIMENSIONS INTÉRIEURES

#length / Länge / longueur : 500 mm #width / Breite / largeur : 350 mm #depth/ Tiefe / profondeur : 110 mm #ø 45 mm

● This washbasin is available in unicolours. / Dieses Waschbecken ist in Uni Colour Farben erhältlich. / Modèle disponible dans les coloris unis.

● This washbasin is available in all granite colours. / Dieses Waschbecken ist in Granitfarben erhältlich. / Modèle disponible dans toutes les nuances de granit



Usability, robustness, easy cleaning, great style and **multiple design options** are all good reason to choose a washbasin or a sink made from Kerrock.

Benutzerfreundlichkeit, Robustheit, einfache Reinigung, hervorragendes **Design und vielfältige Gestaltungsmöglichkeiten** sind gute Gründe, ein Wasch- oder Spülbecken aus Kerrock zu wählen.

Fonctionnalité, résistance, nettoyage facile, belle apparence et **design sont de bonnes raisons** pour choisir une vasque ou un évier Kerrock.

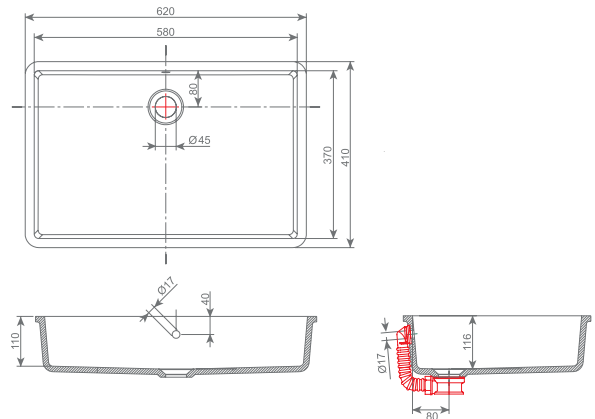

046 LORA

INTERIOR DIMENSIONS / INNENDIMENSIONEN / DIMENSIONS INTÉRIEURES

#length / Länge / longueur : 580 mm #width / Breite / largeur : 370 mm #depth/ Tiefe / profondeur : 110 mm #ø 45 mm

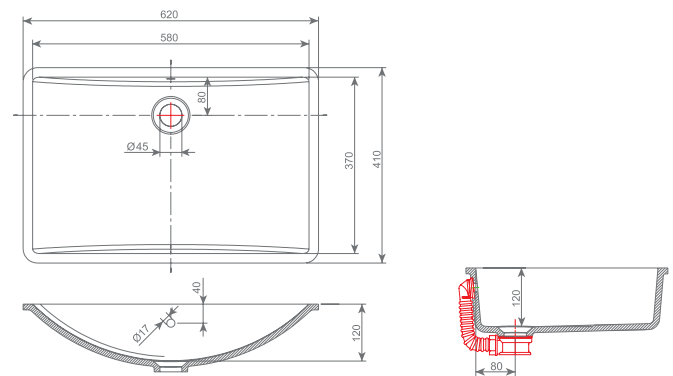

047 KELI

INTERIOR DIMENSIONS / INNENDIMENSIONEN / DIMENSIONS INTÉRIEURES

#length / Länge / longueur : 580 mm #width / Breite / largeur : 370 mm #depth/ Tiefe / profondeur : 120 mm #ø 45 mm

1090, 5080, 5083, 9095 | This washbasin is available in granite colours 1090, 5080, 5083 in 9095. / Dieses Waschbecken ist nur in Granitfarben 1090, 5080, 5083 und 9095 erhältlich. / Modèle disponible uniquement dans les nuances de granit suivantes 1090, 5080, 5083 et 9095.

*Kerrock, born to
beat the average!* “

*Kerrock, entwickelt um den
Durchschnitt zu übertreffen!
Kerrock, créé pour se surpasser !*



Kerrock **washbasins** / Kerrock **Waschbecken** / Ke

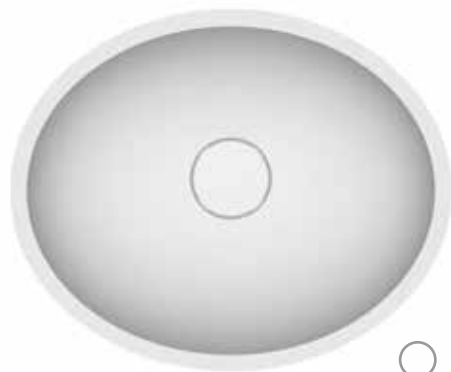

○ 108

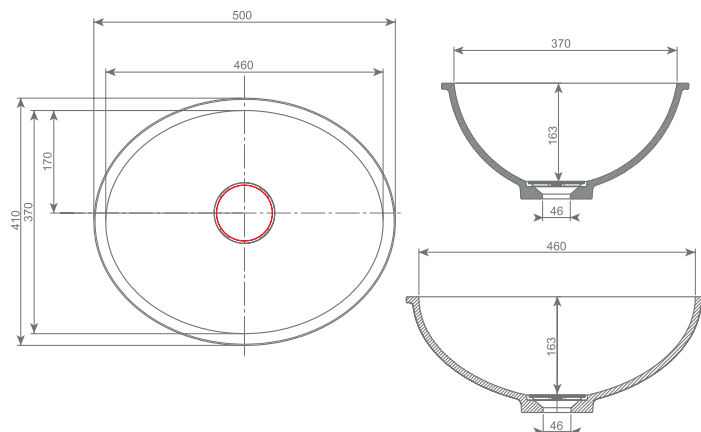

110 VITA

INTERIOR DIMENSIONS / INNENDIMENSIONEN / DIMENSIONS INTÉRIEURES

#length / Länge / longueur : 460 mm #width / Breite / largeur : 370 mm #depth/ Tiefe / profondeur : 163 mm #ø 101 mm

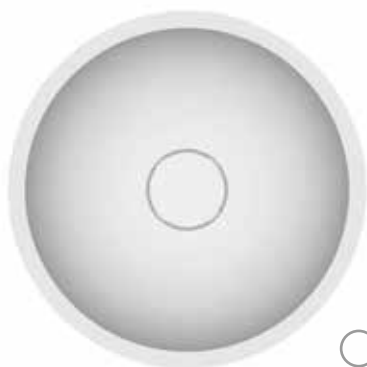

○ 108

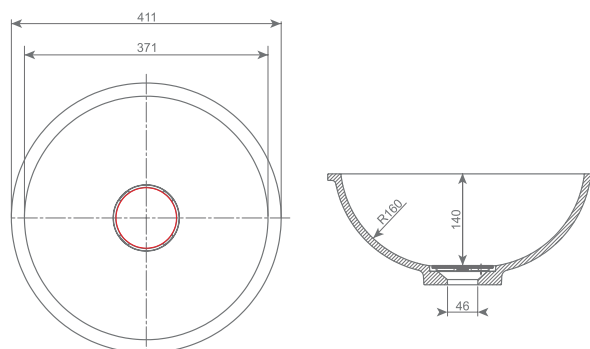

111 IRIS

INTERIOR DIMENSIONS / INNENDIMENSIONEN / DIMENSIONS INTÉRIEURES

#length / Länge / longueur : 371 mm #depth/ Tiefe / profondeur : 140 mm #ø 101 mm



○ 108

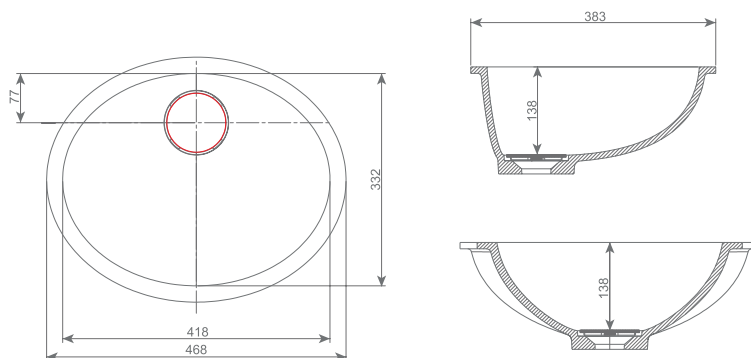

112 ROSA

INTERIOR DIMENSIONS / INNENDIMENSIONEN / DIMENSIONS INTÉRIEURES

#length / Länge / longueur : 418 mm #width / Breite / largeur : 332 mm #depth/ Tiefe / profondeur : 138 mm #ø 101 mm



○ 108

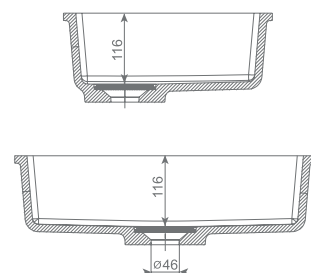
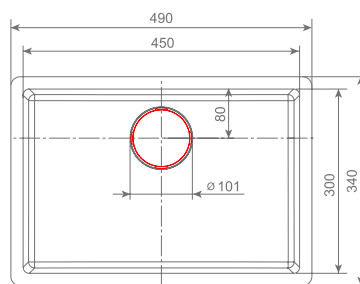

116 BRINA VARIANT

INTERIOR DIMENSIONS / INNENDIMENSIONEN / DIMENSIONS INTÉRIEURES

#length / Länge / longueur : 450 mm #width / Breite / largeur : 300 mm #depth/ Tiefe / profondeur : 116 mm #ø 101 mm



○ 108

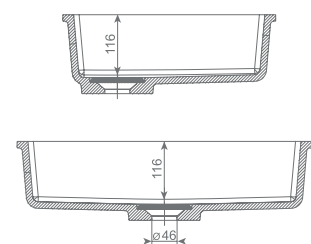
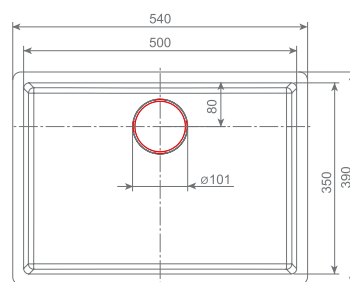

117 CHERI VARIANT

INTERIOR DIMENSIONS / INNENDIMENSIONEN / DIMENSIONS INTÉRIEURES

#length / Länge / longueur : 500 mm #width / Breite / largeur : 350 mm #depth/ Tiefe / profondeur : 116 mm #ø 101 mm



○ 108

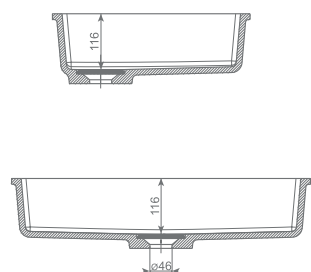
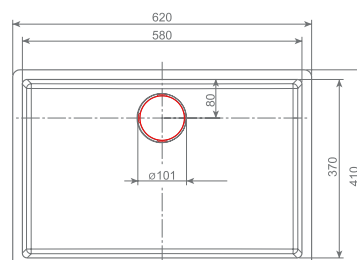

118 LORA VARIANT

INTERIOR DIMENSIONS / INNENDIMENSIONEN / DIMENSIONS INTÉRIEURES

#length / Länge / longueur : 580 mm ##width / Breite / largeur : 370 mm #depth/ Tiefe / profondeur : 116 mm #ø 101 mm

○ 108

This washbasin is available in unicolour 108. / Dieses Waschbecken ist nur in Uni Colour Farbe 108 erhältlich. / Modèle disponible uniquement en coloris unis 108.

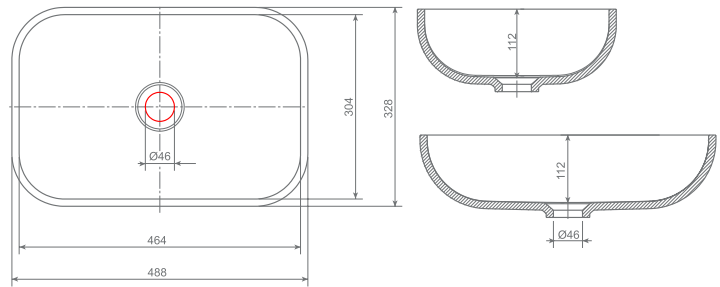

○ KERROCK ES 112 (EASY SHAPING)

129 ZENA 460

INTERIOR DIMENSIONS / INNENDIMENSIONEN / DIMENSIONS INTÉRIEURES

#length / Länge / longueur : 464 mm #width / Breite / largeur : 304 mm #depth/ Tiefe / profondeur : 112 mm #Ø 46 mm

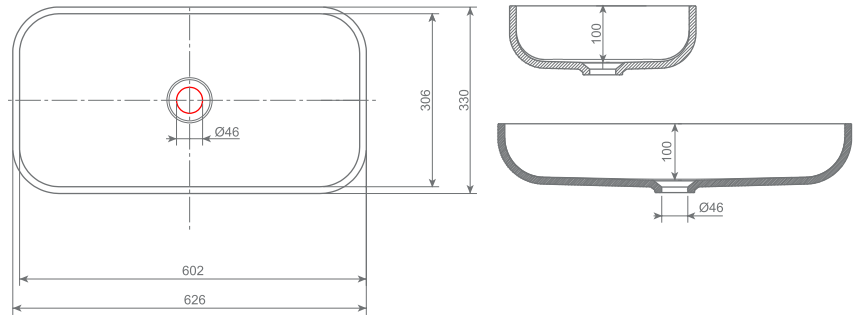

○ KERROCK ES 112 (EASY SHAPING)

130 ZENA 600

INTERIOR DIMENSIONS / INNENDIMENSIONEN / DIMENSIONS INTÉRIEURES

#length / Länge / longueur : 602 mm #width / Breite / largeur : 306 mm #depth/ Tiefe / profondeur : 100 mm #Ø 46 mm

○ KERROCK ES 112 (EASY SHAPING)



*Infinite power of
imagination. “*

*Unendliche Kraft der Phantasie.
L'infini pouvoir de l'imagination.*



○ 108

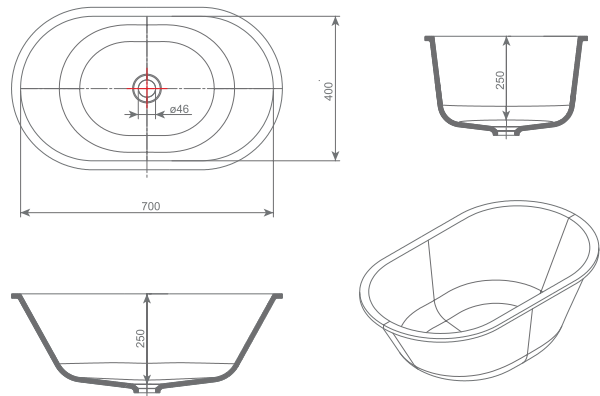

114 SOFIA

INTERIOR DIMENSIONS / INNENDIMENSIONEN / DIMENSIONS INTÉRIEURES

#length / Länge / longueur : 700 mm #width / Breite / largeur : 400 mm #depth/ Tiefe / profondeur : 250 mm #ø 46 mm



○ 108

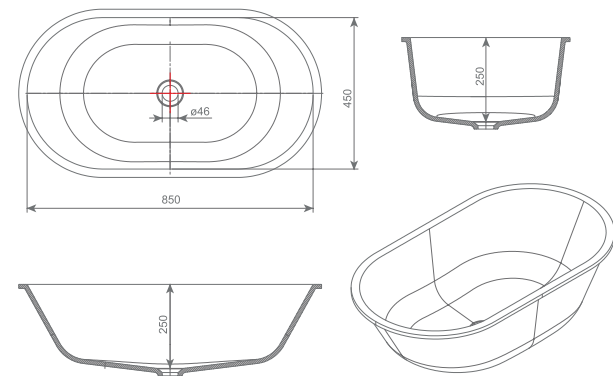

115 ADA

INTERIOR DIMENSIONS / INNENDIMENSIONEN / DIMENSIONS INTÉRIEURES

#length / Länge / longueur : 850 mm #width / Breite / largeur : 450 mm #depth/ Tiefe / profondeur : 250 mm #ø 46 mm

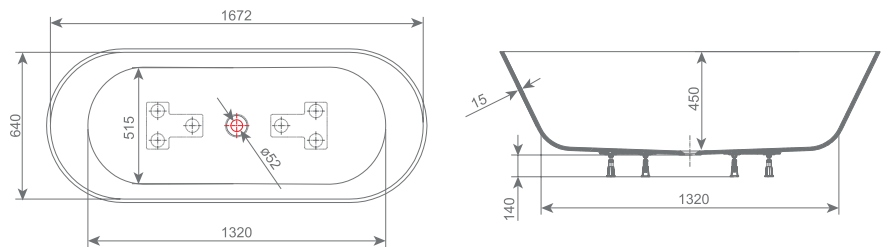

○ 108 / With legs and outflow and overflow click-clack set.
Füße und Ablaufgarnitur Click-Clack beigelegt.
Fournie avec les pieds et le système de vidage-remplissage click-clack.

113 ATYS 1670x640 (450)

INTERIOR DIMENSIONS / INNENDIMENSIONEN / DIMENSIONS INTÉRIEURES

#length / Länge / longueur : 1672 mm #width / Breite / largeur : 640 mm #depth/ Tiefe / profondeur : 450 mm #ø 52 mm

○ 108

This washbasin is available in unicolour 108. / Dieses Waschbecken ist nur in Uni Colour Farbe 108 erhältlich. / Modèle disponible uniquement en coloris unis 108.

TRI-VARIO SERIES

An innovative system that uses different variations of washbasins and their installation to provide highly flexible bathroom design. Meet Kerrock Tri-Vario that gives your imagination new dimensions. You can choose between square, round, and oval shape of washbasins and three options of installation: on, in and below the countertop. With any combination you can thus create a functional and aesthetically harmonious bathroom bearing your signature.

Dieses innovative System ermöglicht mit verschiedenen Waschbecken-variationen und Einbaumöglichkeiten eine außerordentliche Flexibilität bei Badentwurf. Lernen Sie Kerrock tri-vario kennen, das Ihrer Phantasie neue Dimensionen verleiht. Zur Auswahl stehen quadratische, runde oder ovale Form der Waschbecken und drei Einbaumöglichkeiten - über, in und unter den Pult. Mit beliebiger Kombination erstellen Sie sich ein funktionales und ästhetisch harmonisches Bad, dem Sie Ihre persönliche Note verleihen.

Un système innovant qui vous permet, d'obtenir une grande flexibilité dans la conception de votre salle de bains, grâce aux différentes variantes de vasques et à leur installation. Découvrez Kerrock tri-vario, qui donne à votre imagination une nouvelle dimension. Vous pouvez choisir la forme de votre vasque : carrée, ronde ou ovale. Vous disposez de trois options de montage ; au-dessous, sur et au-dessus du plan de travail. Grâce à la combinaison de votre choix, vous pouvez également créer une salle de bains fonctionnelle et esthétiquement harmonieuse qui porte votre signature.

INSTALLATION EXAMPLES

EINBAUMÖGLICHKEITEN EXEMPLES D'INSTALLATIONS

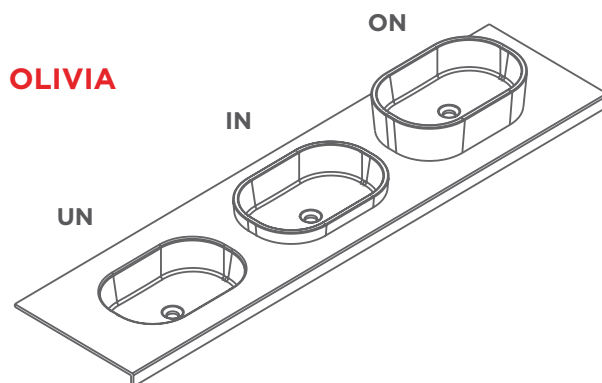
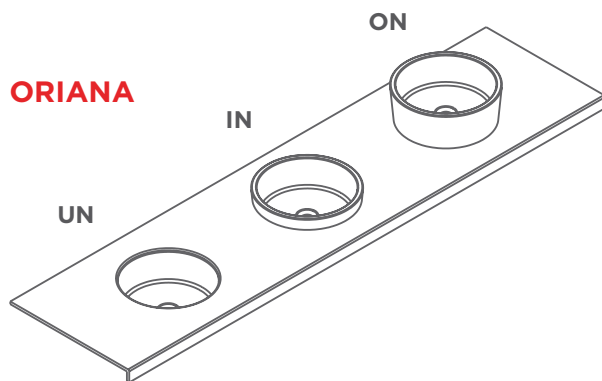
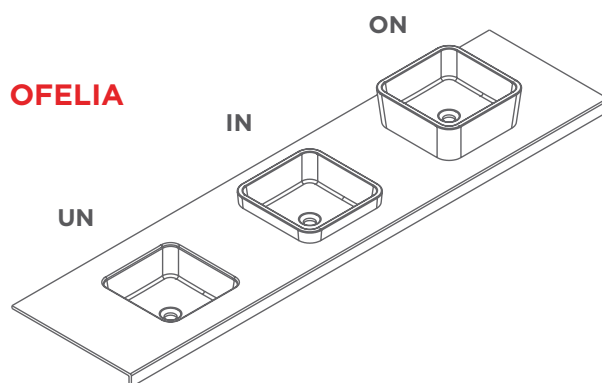

ON - on countertop

IN - in countertop

UN - under countertop



○ 108

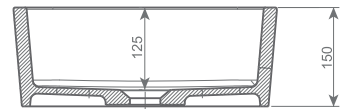
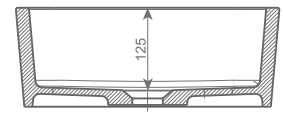
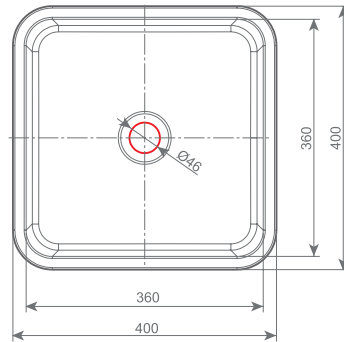

119 OFELIA - ON

INTERIOR DIMENSIONS / INNENDIMENSIONEN / DIMENSIONS INTÉRIEURES

#length / Länge / longueur : 360 mm #width / Breite / largeur : 360 mm #depth/ Tiefe / profondeur : 125 mm #ø 46 mm



○ 108

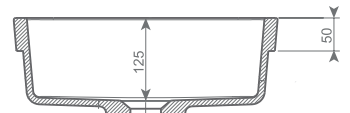
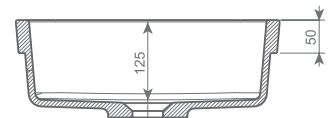
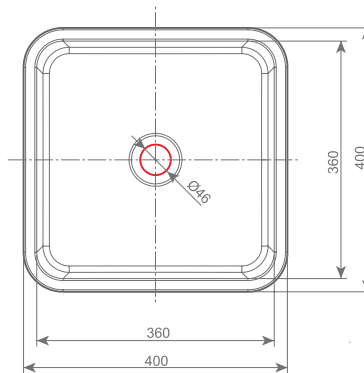

120 OFELIA - IN

INTERIOR DIMENSIONS / INNENDIMENSIONEN / DIMENSIONS INTÉRIEURES

#length / Länge / longueur : 360 mm #width / Breite / largeur : 360 mm #depth/ Tiefe / profondeur : 125 mm #ø 46 mm



○ 108

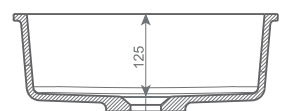
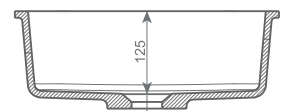
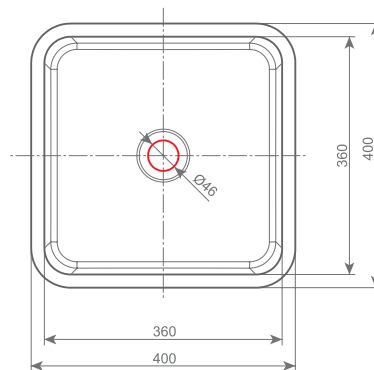

121 OFELIA - UN

INTERIOR DIMENSIONS / INNENDIMENSIONEN / DIMENSIONS INTÉRIEURES

#length / Länge / longueur : 360 mm #width / Breite / largeur : 360 mm #depth/ Tiefe / profondeur : 125 mm #ø 46 mm

○ 108

| This washbasin is available in unicolour 108. / Dieses Waschbecken ist nur in Uni Colour Farbe 108 erhältlich. / Modèle disponible uniquement en coloris unis 108.

TRI-VARIO SERIES



○ 108

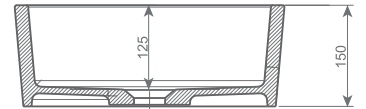
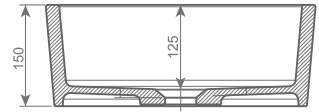
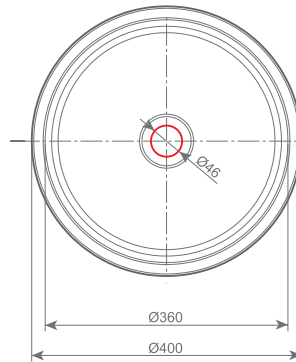

123 ORIANA - ON

INTERIOR DIMENSIONS / INNENDIMENSIONEN / DIMENSIONS INTÉRIEURES

#length / Länge / longueur : 360 mm #depth/ Tiefe / profondeur : 125 mm #ø 46 mm



○ 108

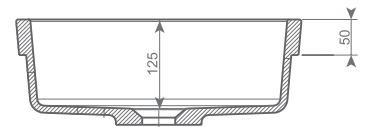
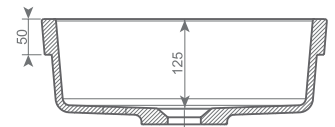
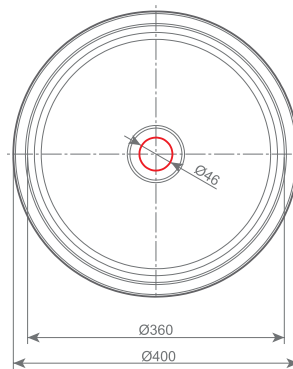

124 ORIANA - IN

INTERIOR DIMENSIONS / INNENDIMENSIONEN / DIMENSIONS INTÉRIEURES

#length / Länge / longueur : 360 mm #depth/ Tiefe / profondeur : 125 mm #ø 46 mm



○ 108

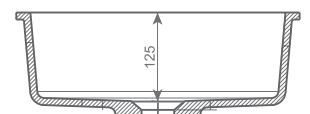
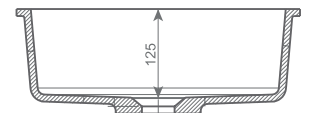
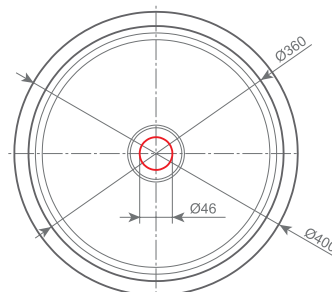

125 ORIANA - UN

INTERIOR DIMENSIONS / INNENDIMENSIONEN / DIMENSIONS INTÉRIEURES

#length / Länge / longueur : 360 mm #depth/ Tiefe / profondeur : 125 mm #ø 46 mm

○ 108

This washbasin is available in unicolour 108. / Dieses Waschbecken ist nur in Uni Colour Farbe 108 erhältlich. / Modèle disponible uniquement en coloris unis 108.

TRI-VARIO SERIES

kerrock®
BY KOLPA



○ 108

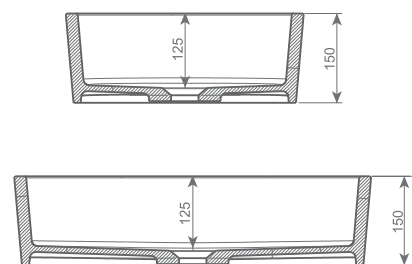
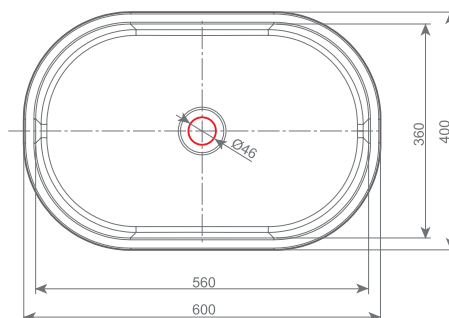

126 OLIVIA - ON

INTERIOR DIMENSIONS / INNENDIMENSIONEN / DIMENSIONS INTÉRIEURES

#length / Länge / longueur : 560 mm #width / Breite / largeur : 360 mm #depth/ Tiefe / profondeur : 125 mm #ø 46 mm



○ 108

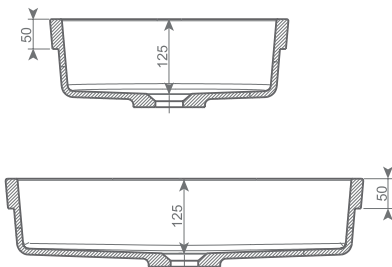
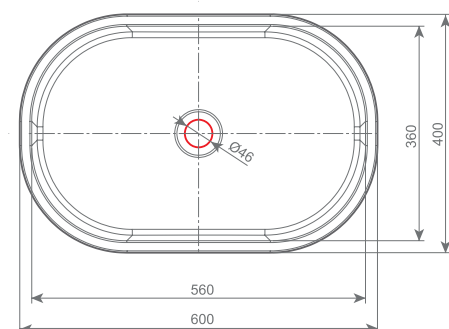

127 OLIVIA - IN

INTERIOR DIMENSIONS / INNENDIMENSIONEN / DIMENSIONS INTÉRIEURES

#length / Länge / longueur : 560 mm #width / Breite / largeur : 360 mm #depth/ Tiefe / profondeur : 125 mm #ø 46 mm



○ 108

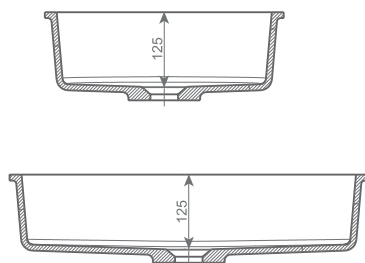
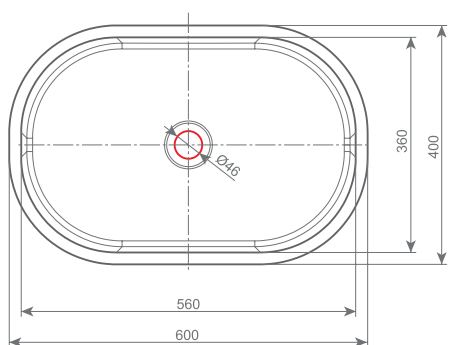

128 OLIVIA - UN

INTERIOR DIMENSIONS / INNENDIMENSIONEN / DIMENSIONS INTÉRIEURES

#length / Länge / longueur : 560 mm #width / Breite / largeur : 360 mm #depth/ Tiefe / profondeur : 125 mm #ø 46 mm

○ 108

| This washbasin is available in unicolour 108. / Dieses Waschbecken ist nur in Uni Colour Farbe 108 erhältlich. / Modèle disponible uniquement en coloris unis 108.



WASHBASINS ACCORDING TO YOUR WISHES

The table below shows an example of a few additional dimensions of Lina and Luna washbasins. Based on technical drawings we can create for you a washbasin of custom dimensions.

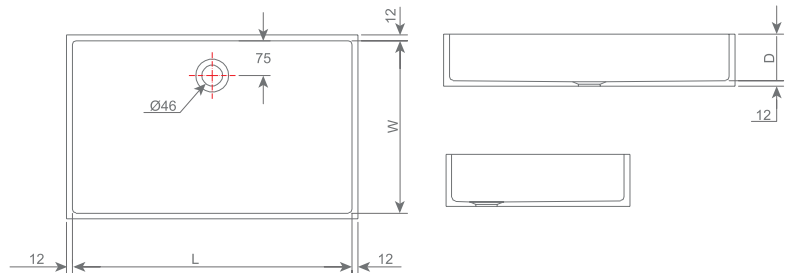

145 LINA

STANDARD DIMENSIONS / STANDARD DIMENSIONEN / DIMENSIONS STANDARD (L / W / D / fi)

LINA 300 / 300 / 120 / 46	LINA 300 / 350 / 120 / 46	LINA 300 / 370 / 120 / 46
LINA 400 / 300 / 120 / 46	LINA 400 / 350 / 120 / 46	LINA 400 / 370 / 120 / 46
LINA 500 / 300 / 120 / 46	LINA 500 / 350 / 120 / 46	LINA 500 / 370 / 120 / 46
LINA 600 / 300 / 120 / 46	LINA 600 / 350 / 120 / 46	LINA 600 / 370 / 120 / 46

DIMENSIONS BY ORDER / DIMENSION NACH BESTELLUNG / DIMENSIONS SUR DEMANDE (L / W / D / fi)

	L (LENGTH / LÄNGE / LONGUEUR)	W (WIDTH / BREITE / LARGEUR)	D (DEPTH / TIEFE / PROFONDEUR)
LINA	300 - 1200	300 - 600	50 - 500



WACHBECKEN KOMPLETT NACH IHREN WÜNSCHEN

In der unteren Tabelle gibt es einige zusätzliche Dimensionen der Waschbecken Lina und Luna. Natürlich ist es auch möglich aufgrund der technischen Skizze ein Waschbecken in einer Dimension nach Maß anzufertigen.

DES VASQUES SELON VOS ENVIES

Le tableau ci-dessous montre un exemple de dimensions possibles des vasques Lina et Luna. Bien sûr, nous pouvons également créer une vasques aux dimensions personnalisées sur la base de dessins techniques.

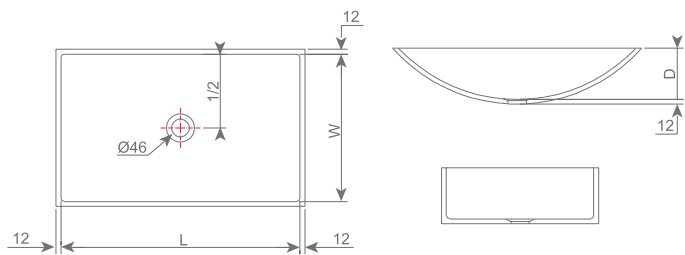

146 LUNA

STANDARD DIMENSIONS / STANDARD DIMENSIONEN / DIMENSIONS STANDARD (L / W / D / fi)

LUNA 300 / 300 / 120 / 46	LUNA 300 / 350 / 120 / 46	LUNA 300 / 370 / 120 / 46
LUNA 400 / 300 / 120 / 46	LUNA 400 / 350 / 120 / 46	LUNA 400 / 370 / 120 / 46
LUNA 500 / 300 / 120 / 46	LUNA 500 / 350 / 120 / 46	LUNA 500 / 370 / 120 / 46
LUNA 600 / 300 / 120 / 46	LUNA 600 / 350 / 120 / 46	LUNA 600 / 370 / 120 / 46

DIMENSIONS BY ORDER / DIMENSION NACH BESTELLUNG / DIMENSIONS SUR DEMANDE (L / W / D / fi)

	L (LENGTH / LÄNGE / LONGUEUR)	W (WIDTH / BREITE / LARGEUR)	D (DEPTH / TIEFE / PROFONDEUR)
LUNA	300 - 1200	300 - 600	50 - 250



Washbasins available in unicolours, granite and terraco colours. / D er Waschbecken ist in Uni Colour Farben, Granit- sowie Teraco-Farben erhältlich. / Modèle disponible en coloris unis, granit et terraco.



WASHBASIN FOR DISABLED

In our company, we pay special attention to people with disabilities. Washbasins for disabled people must allow enough space for the knees and thighs, while the drain should be positioned as close to the wall as possible. The height of the latter depends on the height of the user in a wheelchair and ranges between 65 and 70 cm.

BEHINDERTEGERECHTER WASHBECKEN

In unserem Unternehmen widmen wir viel Aufmerksamkeit auch behinderten Menschen. Behindertengerechter Waschbecken soll genügend Platz für Knien und Oberschenkel ermöglichen. Der Ablauf ist so nah wie möglich an die Wand positioniert. Die Höhe des Ablaufs hängt von der Größe des im Rollstuhl sitzenden Benutzers ab und beträgt zwischen 65 und 70 cm.

VASQUE ADAPTÉE AUX PERSONNES HANDICAPÉES

Dans notre société, nous portons une attention particulière aux personnes handicapées. Les vasques conçues pour les personnes handicapées doivent laisser suffisamment d'espace pour les genoux et les cuisses, et le tuyau doit être positionné le plus près du mur. La hauteur de la vasque est dépendante de la taille de la personne en fauteuil roulant, mais elle varie entre 65 et 70 cm.

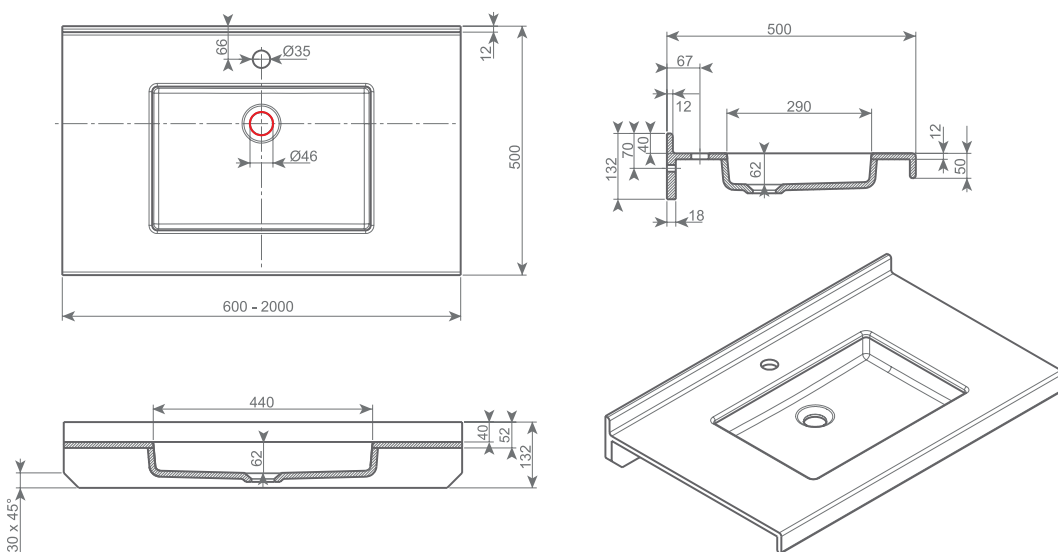

147

INSTALLATION DIMENSIONS
EINBAUDIMENSIONEN
DIMENSIONS DE L'INSTALLATION :
#length / Länge / longueur : 600 - 2000 mm
#width / Breite / largeur : 500 mm

○ 108

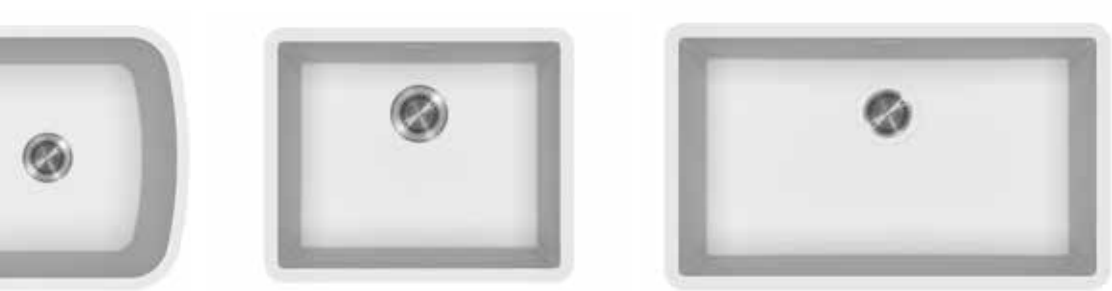

KITCHEN SINKS

SPÜLBECKEN ÉVIERS DE CUISINE



A day, starting with a fragrant cup of coffee and a look at the beautiful shapes of Kerrock, is a good day.

Health-friendly, resistant to mechanical impact, and of great aesthetics. The Kerrock kitchen.

Der Tag, der mit einem herrlich duftenden Tasse Kaffee und mit dem Blick auf die schönen Formen von Kerrock anfängt, wird ein angenehmer Tag sein.

Gesundheitsfreundlich, umweltfreundlich, mechanisch fest und zeitlos. Eine Kerrock Küche.

Commencer la journée avec une tasse de café parfumé et le regard posé sur de magnifiques formes en Kerrock, c'est commencer une bonne journée.

Sain et résistant aux chocs, avec un esthétique immense. La cuisine Kerrock.

Ihre Küche ist das Herz Ihres Hause. Mit Kerrock wird sie perfekt aussehen.

La cuisine est le cœur de la maison. Elle se transforme en amour grâce au Kerrock.



*Kitchen is the heart of your home.
With Kerrock it becomes love.*



Kerrock **kitchen sinks** / Kerrock **Spülbecken** / Kerrock



○ 108

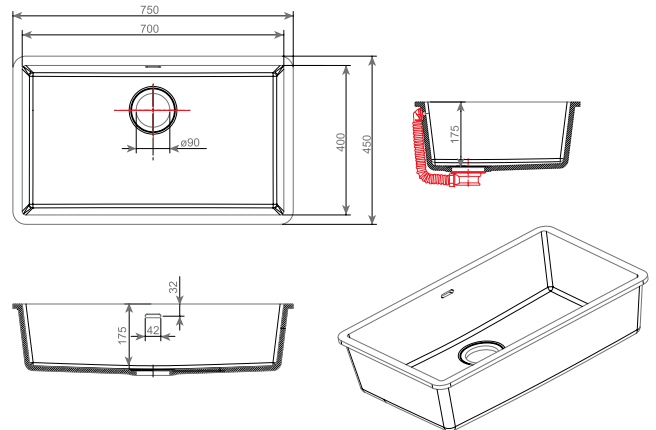

131 BETA

INTERIOR DIMENSIONS / INNENDIMENSIONEN / DIMENSIONS INTÉRIEURES

#length / Länge / longueur : 700 mm #width / Breite / largeur : 400 mm #depth/ Tiefe / profondeur : 175 mm #ø 90 mm



○ 108

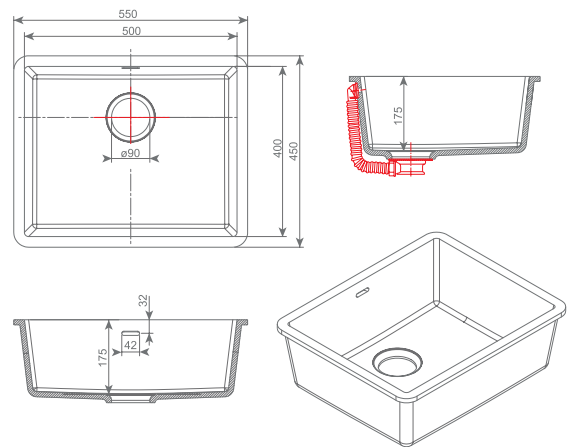

132 CORA

INTERIOR DIMENSIONS / INNENDIMENSIONEN / DIMENSIONS INTÉRIEURES

#length / Länge / longueur : 500 mm #width / Breite / largeur : 400 mm #depth/ Tiefe / profondeur : 175 mm #ø 90 mm



○ 108

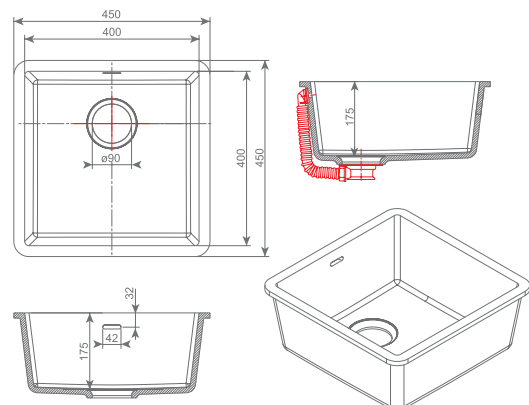

133 FLORA

INTERIOR DIMENSIONS / INNENDIMENSIONEN / DIMENSIONS INTÉRIEURES

#length / Länge / longueur : 400 mm #width / Breite / largeur : 400 mm #depth/ Tiefe / profondeur : 175 mm #ø 90 mm

○ 108

This sink is available in unicolour 108. / Dieses Spülbecken ist nur in Farbe 108 erhältlich. / Modèle disponible uniquement en coloris unis 108.



○ 108

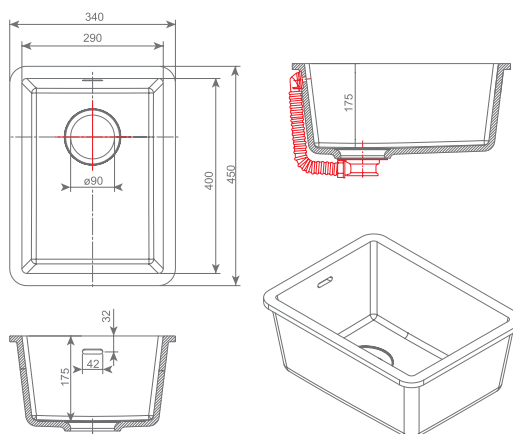

134 ALYA

INTERIOR DIMENSIONS / INNENDIMENSIONEN / DIMENSIONS INTÉRIEURES

#length / Länge / longueur : 290mm #width / Breite / largeur : 400 mm #depth/ Tiefe / profondeur : 175 mm #ø 90 mm



○ 108

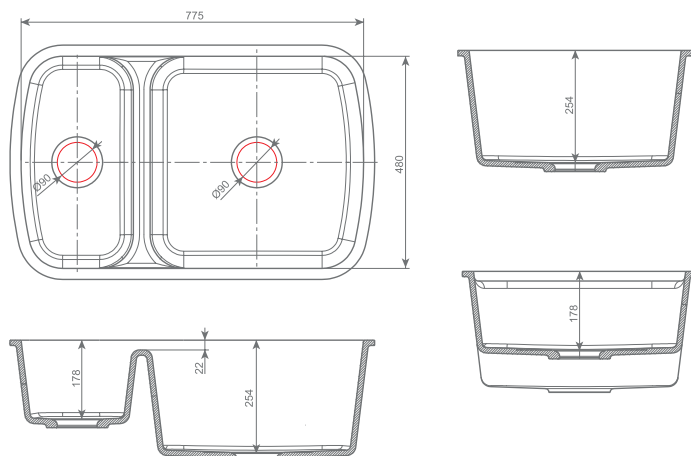

135 CARLA

INTERIOR DIMENSIONS / INNENDIMENSIONEN / DIMENSIONS INTÉRIEURES

#length / Länge / longueur : 775 mm #width / Breite / largeur : 480 mm #depth/ Tiefe / profondeur : 254 mm #ø 90 mm



○ 108

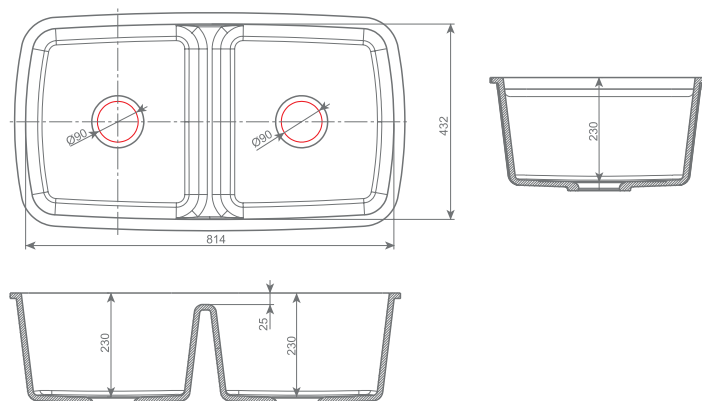

136 BINA

INTERIOR DIMENSIONS / INNENDIMENSIONEN / DIMENSIONS INTÉRIEURES

#length / Länge / longueur : 810 mm #width / Breite / largeur : 430 mm #depth/ Tiefe / profondeur : 230 mm #ø 90 mm

Kerrock **kitchen sinks** / Kerrock **Spülbecken** / Kerrock



○ 108

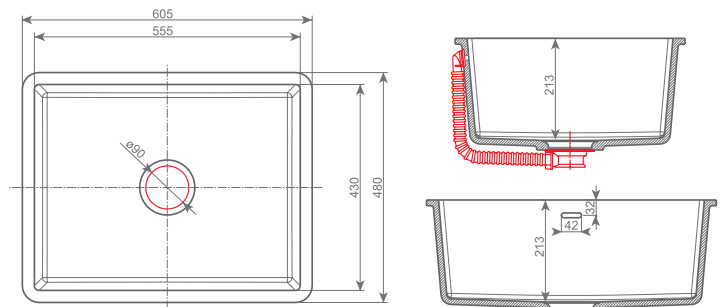

137 KHLOE

INTERIOR DIMENSIONS / INNENDIMENSIONEN / DIMENSIONS INTÉRIEURES

#length / Länge / longueur : 555 mm #width / Breite / largeur : 430 mm #depth/ Tiefe / profondeur : 213 mm #ø 90 mm



○ 108

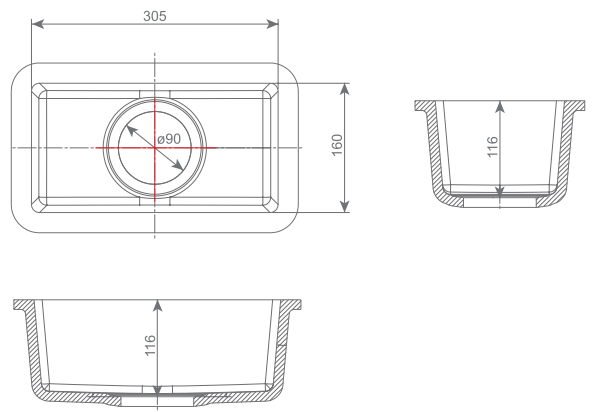

138 PIKA

INTERIOR DIMENSIONS / INNENDIMENSIONEN / DIMENSIONS INTÉRIEURES

#length / Länge / longueur : 305 mm #width / Breite / largeur : 160 mm #depth/ Tiefe / profondeur : 116 mm #ø 90 mm



○ 108

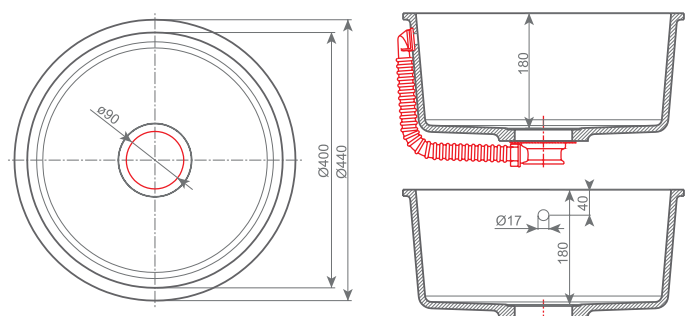

122 ALITA

INTERIOR DIMENSIONS / INNENDIMENSIONEN / DIMENSIONS INTÉRIEURES

#length / Länge / longueur : 400 mm #depth/ Tiefe / profondeur : 180 mm #ø 90 mm

○ 108

This sink is available in unicolour 108. / Dieses Spülbecken ist nur in Farbe 108 erhältlich. / Modèle disponible uniquement en coloris unis 108.



● ● 1090, 5080,
5083, 9095

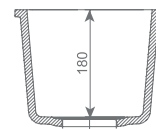
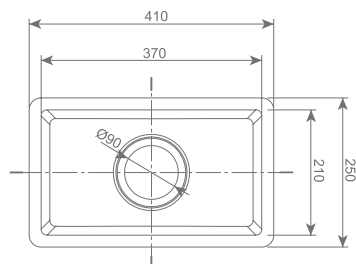

059 SONIA

INTERIOR DIMENSIONS / INNENDIMENSIONEN / DIMENSIONS INTÉRIEURES

#length / Länge / longueur : 370 mm #width / Breite / largeur : 210 mm #depth/ Tiefe / profondeur : 180 mm #ø 90 mm



● ● 1090, 5080,
5083, 9095

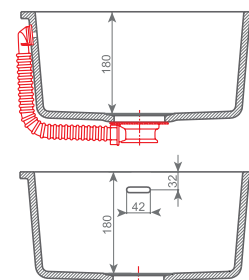
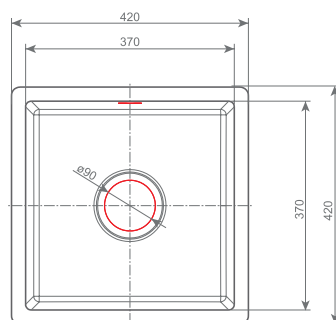

060 EMMA

INTERIOR DIMENSIONS / INNENDIMENSIONEN / DIMENSIONS INTÉRIEURES

#length / Länge / longueur : 370 mm #width / Breite / largeur : 370 mm #depth/ Tiefe / profondeur : 180 mm #ø 90 mm



● ● 1090, 5080,
5083, 9095

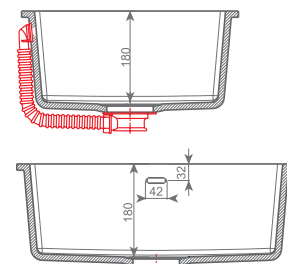
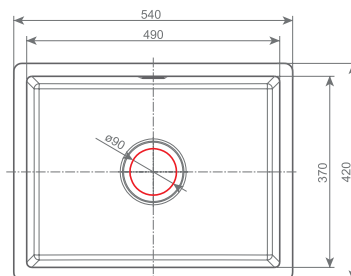

061 NADIA

INTERIOR DIMENSIONS / INNENDIMENSIONEN / DIMENSIONS INTÉRIEURES

#length / Länge / longueur : 490 mm #width / Breite / largeur : 370 mm #depth/ Tiefe / profondeur : 180 mm #ø 90 mm

● This sink is available in unicolours. / Dieses Spülbecken ist in Uni Colour Farben erhältlich. / Modèle disponible dans les coloris unis.

● 1090, 5080, 5083, 9095 | This sink is available in granite colours 1090, 5080, 5083 in 9095. / Das Spülbecken nur in Granitfarben 1090, 5080, 5083 und 9095 erhältlich. / Modèle disponible uniquement dans les nuances de granit suivantes 1090, 5080, 5083 et 9095.

Actual dimensions may vary from stated ones (the plan). Dimensions können von den angegebenen abweichen (vom Entwurf). Les dimensions réelles peuvent différer (de ceux du plan).

KERROCK INNOXATION

Kerrock and Inox. United in a symbiosis of functionality and aesthetics. In a play of unusual yet so sensible. For those who want to stand out in an innovative intertwining of two materials. Interweaving that forms a new image of the future. Your kitchen.

Kerrock und Inox. Vereint in Symbiose der Funktionalität und der Ästhetik. Ein Spiel des der Ungewöhnlichen und gleichzeitig so Sinnvolles. Für alle, die zwei verschiedene Materialien auf eine innovative Art und Weise verbinden möchten – eine neue zukünftige Gestaltung. Ihrer Küche.

Kerrock et Inox. Unis dans une symbiose de fonctionnalité et d'esthétisme. Un jeu insolite et pertinent à la fois. Pour ceux qui souhaitent un entrecroisement innovant de deux matériaux. Un entrecroisement pour former une nouvelle image de l'avenir. Votre cuisine.



Sink available in unicolours, granite and ter

142 ELLA 180

INTERIOR DIMENSIONS
INNENDIMENSIONEN
DIMENSIONS INTÉRIEURES

- #length / Länge / longueur : 402 mm
- #width / Breite / largeur : 182 mm
- #depth/ Tiefe / profondeur : 178 mm
- # \varnothing 90 mm

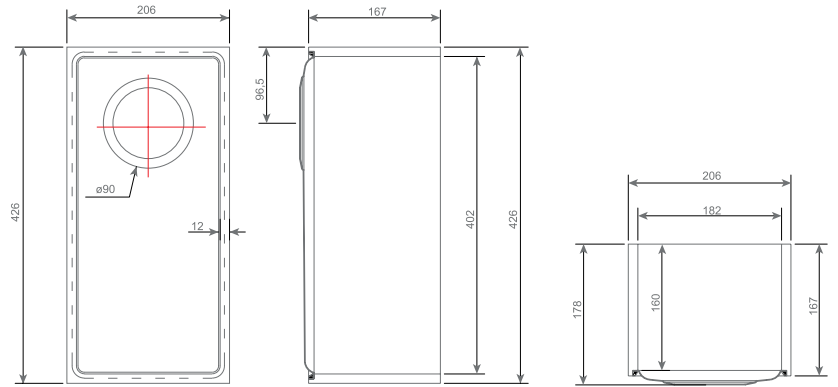

143 ELLA 340

INTERIOR DIMENSIONS
INNENDIMENSIONEN
DIMENSIONS INTÉRIEURES

- #length / Länge / longueur : 402 mm
- #width / Breite / largeur : 342 mm
- #depth/ Tiefe / profondeur : 178 mm
- # \varnothing 90 mm

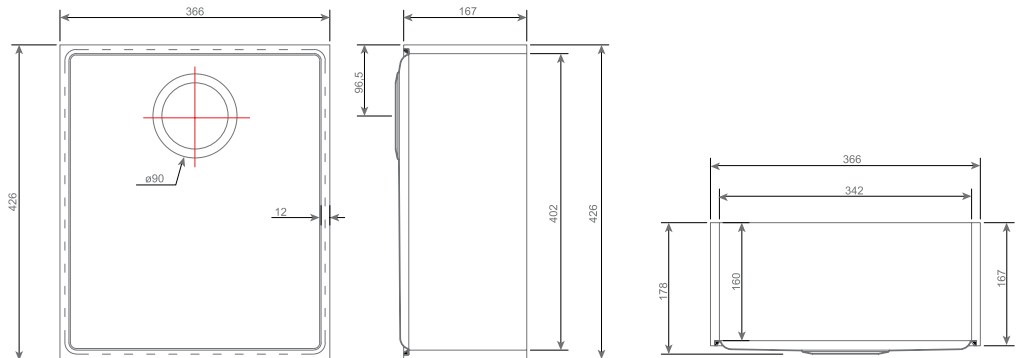

144 ELLA 400

INTERIOR DIMENSIONS
INNENDIMENSIONEN
DIMENSIONS INTÉRIEURES

- #length / Länge / longueur : 402 mm
- #width / Breite / largeur : 402 mm
- #depth/ Tiefe / profondeur : 178 mm
- # \varnothing 90 mm

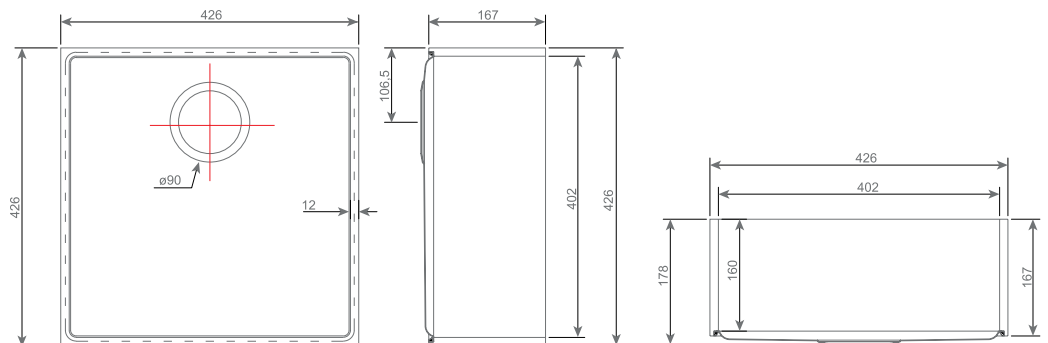

Actual dimensions may vary from stated ones (the plan). Dimensionen können von den angegebenen abweichen (vom Entwurf). Les dimensions réelles peuvent différer (de celles du plan).

Sinks for LABORATORIES and MEDICINE

Washbasins whose speciality is ergonomic adaptability for the use in medicine and laboratories.

Waschbecken für LABORS und MEDIZIN

Eine Besonderheit der Waschbecken ist ergonomische Anpassung den medizinischen und Laborsbedürfnissen.

VASQUES pour LABORATOIRES et pour LES MILIEUX MÉDICAUX

La caractéristique de ces vasques est la capacité d'adaptation ergonomique pour une utilisation en milieu médical et dans les laboratoires.



○ 108

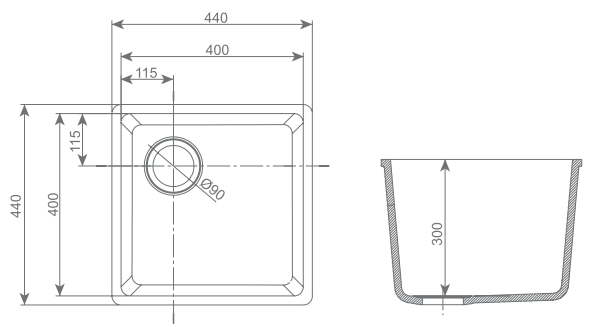

058 AVA

INTERIOR DIMENSIONS / INNENDIMENSIONEN / DIMENSIONS INTÉRIEURES

#length / Länge / longueur : 400 mm #width / Breite / largeur : 400 mm #depth/ Tiefe / profondeur : 300 mm #ø 90 mm

○ 108

This sink is available in unicolour 108. / Dieses Spülbecken ist nur in Farbe 108 erhältlich. / Cuve disponible uniquement en coloris unis 108.



○ 108

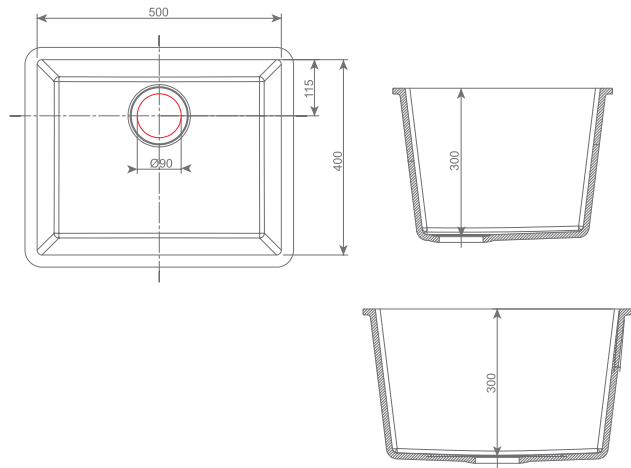

139 CARA

INTERIOR DIMENSIONS / INNENDIMENSIONEN / DIMENSIONS INTÉRIEURES

#length / Länge / longueur : 500 mm #width / Breite / largeur : 400 mm #depth/ Tiefe / profondeur : 300 mm #ø 90 mm



○ 108

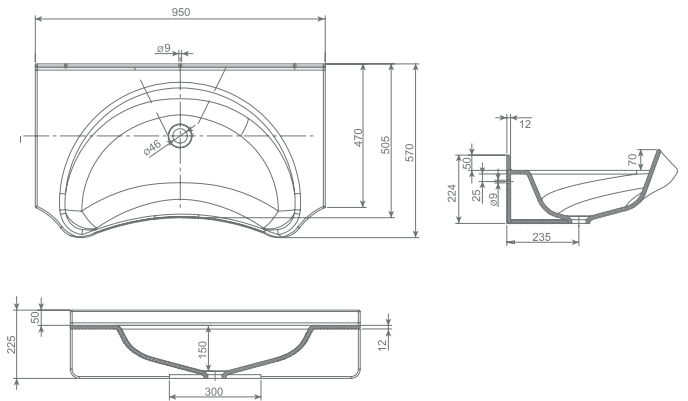

140 HIGIEA

INTERIOR DIMENSIONS / INNENDIMENSIONEN / DIMENSIONS INTÉRIEURES

#length / Länge / longueur : 950 mm #width / Breite / largeur : 570 mm #depth/ Tiefe / profondeur : 150mm #ø 46 mm



○ 108

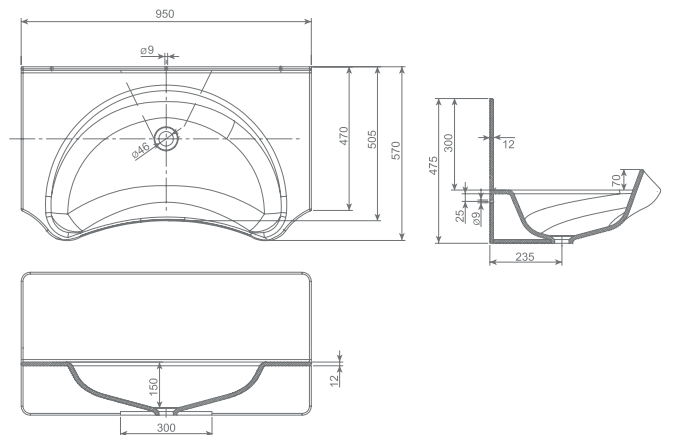

141 STERILIA

INTERIOR DIMENSIONS / INNENDIMENSIONEN / DIMENSIONS INTÉRIEURES

#length / Länge / longueur : 950 mm #width / Breite / largeur : 570 mm #depth/ Tiefe / profondeur : 150 mm #ø 46 mm

“ *Live your life. In colours!* ”

Kerrock Sheets Colour Chart: /
Kerrock-Platten Farbkarte: / Gamme
de couleurs Kerrock :

- Unicolour effects / Uni Colour Effekte / Unis
- Granite effects/Granit-Effekte/Effets granit
- Teraco effects / Teraco-Effekte / Effets terraco
- Marble effects - new / Marmor-Effekte - neu / Effets marbre - nouveau
- Lumino
- Luminaco - new / neu / nouveau



Modern in colours and structure.

KERROCK.

Our general well-being is significantly affected by the surrounding materials. This is why these should be pleasant to the touch, health-friendly and, in particular, colour-coordinated with the surroundings.

An appropriate selection of colours affects both the harmony of the space and relationships between its occupants. **With its wide range of colours**, Kerrock allows creating the interior in which usability and creativity come to life. Suitable for all panels and surfaces that are not exposed to abrasion.



Moderne Farben und Strukturen. KERROCK.



Materialien, die uns umgeben, beeinflussen unser allgemeines Wohlbefinden wesentlich. Deswegen sollten sich diese angenehm anfühlen, gesundheitsfreundlich, aber vor allem mit der Umgebung farblich abgestimmt sein.

Durch eine entsprechende Auswahl von Farbtönen wird nicht nur die Harmonie des Raumes als Ganzes beeinflusst, sondern auch das Wohlbefinden der Person darin. Mit einer breiten Auswahl an Farben lässt Kerrock einen Raum entstehen, in dem der Nutzwert und die Kreativität zum Ausdruck kommen. Für sämtliche Beläge und Flächen geeignet, die dem Verschleiß nicht ausgesetzt sind.

Des couleurs et une structure modernes.

KERROCK.

Les matériaux et les couleurs qui nous entourent ont une grande influence sur notre bien-être, c'est pourquoi ils doivent être agréables au toucher, sains et parfaitement assortis à leur environnement.

Un choix de couleurs adaptées harmonise un espace tout entier et apaise les personnes qui y évoluent. **Kerrock offre une vaste palette de couleurs** permettant de réaliser des espaces où se mêlent utilité et créativité.

Colour range for **washbasins and kitchen sinks** / Farbpalette für **Wasch- und S**

UNICOLOUR EFFECTS / UNI COLOUR EFFEKTE / UNIS

thickness of sheets / Plattendicke / Epaisseur des panneaux : 6, 8, 12, 18 mm

dimensions of sheets / Dimensionen der Platten / Dimensions des panneaux : 3600 x 1350 mm & 3600 x 760 mm

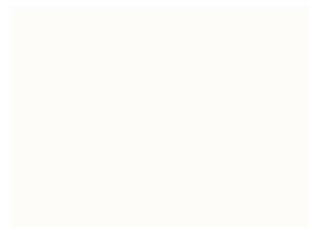

arctic white
100

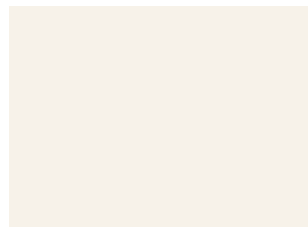

polar white
101



snow white
108

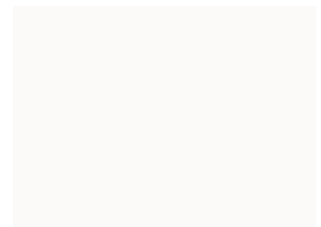

dusty white
117



pearl white
118



lemon
201



orange
300



cherry
400



violet
412

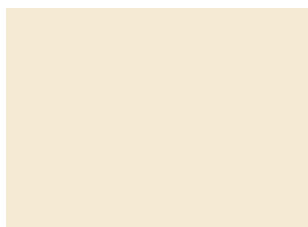

vanilla
500

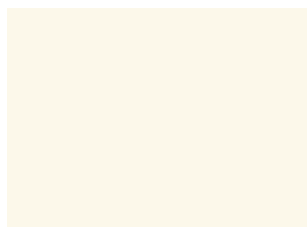

french vanilla
501

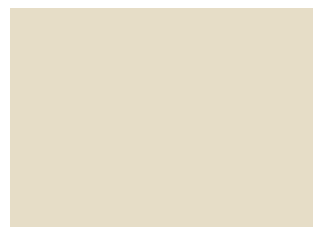

bone
502

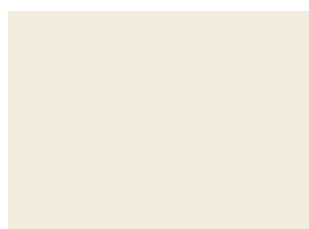

bisque
503

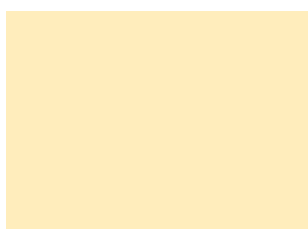

cream
506

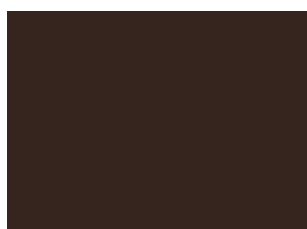

brown cream
509

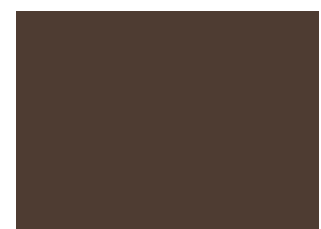

desert rose
512

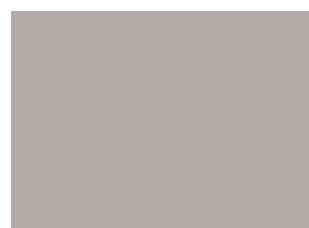

gray quartzite
513



sandstone
514



dolerit
515



merlot
522

Colour hues shown in this catalogue may vary from the actual ones for printing reasons. Samples are displayed in the scale of 1:1.
Die in diesem Katalog gezeigten Farbtöne können sich druckbedingt von den tatsächlichen unterscheiden. Die Muster sind in der Skala 1:1 präsentiert.
Les couleurs présentées dans ce catalogue peuvent différer quelque peu des couleurs réelles en raison de l'impression. Les échantillons sont présentés à l'échelle de 1:1.

UNICOLOUR EFFECTS / UNI COLOUR EFFEKTE / UNIS

thickness of sheets / Plattendicke / Epaisseur des panneaux : 6, 8, 12, 18 mm

dimensions of sheets / Dimensionen der Platten / Dimensions des panneaux : 3600 x 1350 mm & 3600 x 760 mm

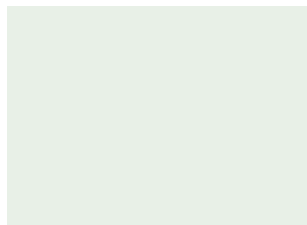

pistachio
601



lime
605



grassy green
620



summer green
621



deep blue
703



ocean
709



midnight sky
710



smokey blue
717

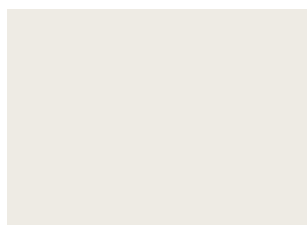

misty grey
900



ash grey
901

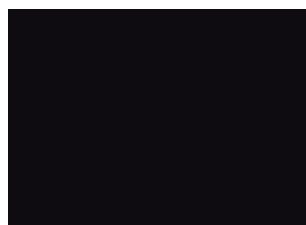

black
909



gypsum
921



water stone
922



charcoal
923

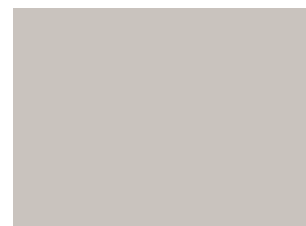

beigeing
924

“ *Leben Sie Ihr Leben. In Farbe!* ”

Colour range for **washbasins and kitchen sinks** / Farbpalette für **Wasch- und S**

GRANITE EFFECTS / GRANIT-EFFEKTE / EFFETS GRANIT

thickness of sheets / Plattendicke / Epaisseur des panneaux : 6, 8, 12, 18 mm

dimensions of sheets / Dimensionen der Platten / Dimensions des panneaux : 3600 x 1350 mm & 3600 x 760 mm



wollastonite
1076

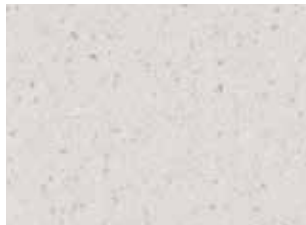

dolomite grain
1087



iceland
1090



salt and peper
1091



hematite
1092



pyrite
1093



tourmaline
1099

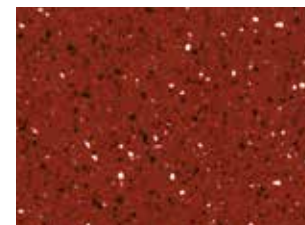

jaspis
4094



phenakite
5075



desert gold
5080



sunrise
5081



giadelite
5083



moonstone
5090



limonite
5091



hiddenite
5092



chrysoprase
5098



magnetite
5191



boehmite
5192



rhyolite
5194

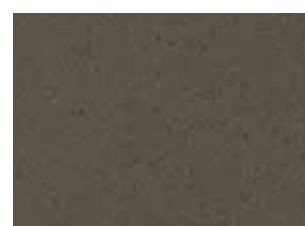

basalt
5195

Colour hues shown in this catalogue may vary from the actual ones for printing reasons. Samples are displayed in the scale of 1:1.
Die in diesem Katalog gezeigten Farbtöne können sich druckbedingt von den tatsächlichen unterscheiden. Die Muster sind in der Skala 1:1 präsentiert.
Les couleurs présentées dans ce catalogue peuvent différer quelque peu des couleurs réelles en raison de l'impression. Les échantillons sont présentés à l'échelle de 1:1.

GRANITE EFFECTS / GRANIT-EFFEKTE / EFFETS GRANIT

thickness of sheets / Plattendicke / Epaisseur des panneaux : 6, 8, 12, 18 mm

dimensions of sheets / Dimensionen der Platten / Dimensions des panneaux : 3600 x 1350 mm & 3600 x 760 mm

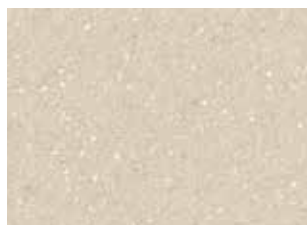

cryolite
5196

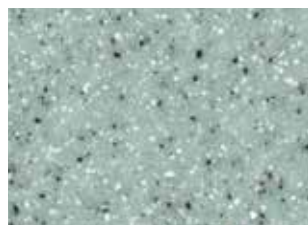

aquamarine
6091



serpentinite
6093



hedenbergit
9011

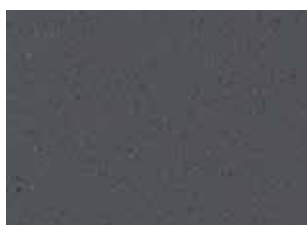

kyanite
9081



leucite
9082



harmotom
9092



molibdenite
9095



onyx
9099

KERROCK ES 112
(EASY SHAPING)

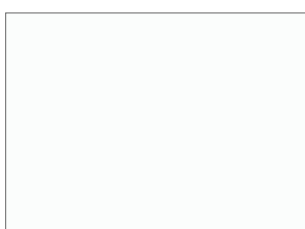

ES
112



Shines in creativity!

Glänzen Sie durch Ihre Kreativität!

Rayonnez En couleurs !

Colour range for **washbasins and kitchen sinks** / Farbpalette für **Wasch- und Spülbecken** / Couleurs pour les **vasques** de salle de bains et les **cuves** de cuisine

TERACO EFFECTS / TERACO EFFEKTE / EFFETS TERRACO

thickness of sheets / Plattendicke / Epaisseur des panneaux : 12 mm, 18* mm (*only 3600 x 760 mm)

dimensions of sheets / Dimensionen der Platten / Dimensions des panneaux : 3600 x 1350 mm & 3600 x 760 mm



quartz
1050



aragonite
1052

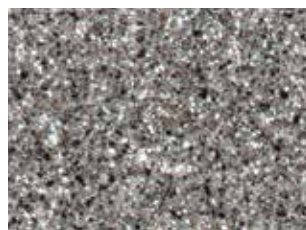

granulite
1055

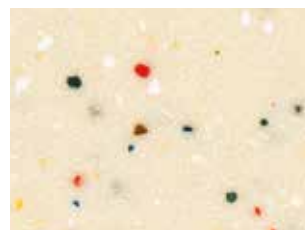

marble*
2052



cabazit
5051



calcite
5053



monte carlo
5055



morocco
5057

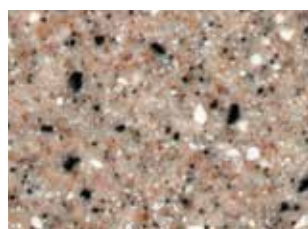

spesartin
5059



albit
5061



barcelona
5062



semolina
5064

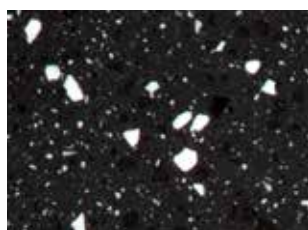

obsidian
9050

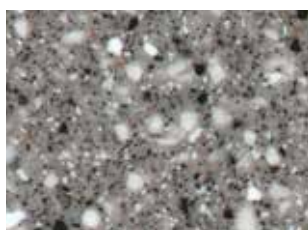

rolling stone
9057

* 2052 Marble available only for the thickness of 12 mm and dimension of 3600 x 760 mm.

* 2052 Marble nur in einer Stärke von 12 mm und Dimension 3600 x 760 mm erhältlich.

* Décor marbre 2052 uniquement disponible au format 3600 x 760 mm dans l'épaisseur 12 mm.

“ Rayonnez. *En couleurs!* ”

Universal siphons

Universal **Siphons** / **Siphons** universels

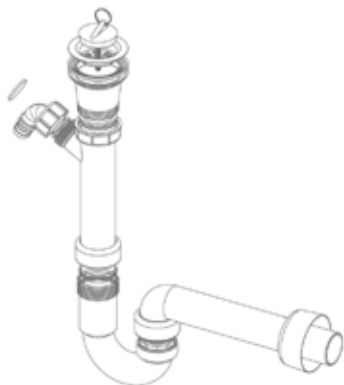

SIF-UM/45; id. 6510

- ø 45-siphon for the following washbasins
- Siphon ø 45 für Waschbecken
- siphon ø 45 pour les vasques

SILVIA, TINA, PETRA, TRU, SARA, BLANCA, LANA, EVA, MAJA, IVA, ANA, RONDO, META, KERI, JANA, BARBI, AJDA, BEA, BRINA, CHERI, KELI, LORA, VITA, IRIS, ROSA, BRINA VARIANT, CHERI VARIANT, LORA VARIANT, ZENA 460, ZENA 600, OFELIA ON, OFELIA IN, OFELIA UN, ORIANA ON, ORIANA IN, ORIANA UN, OLIVIA ON, OLIVIA IN, OLIVIA UN, LINA, LUNA, HIGIEA, STERILIA

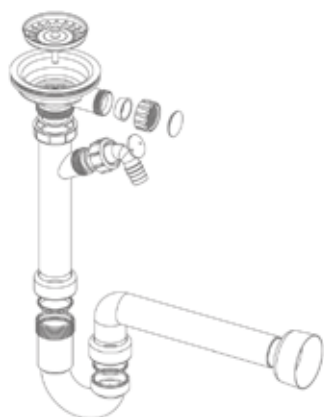

SIF-UM/90; id. 214640

- ø 90-siphon for the kitchen sink with or without the overflow
- Siphon ø 90 für Spülbecken mit oder ohne Überfluss
- siphon ø 90 pour les cuves avec ou sans trop-plein

BETA, CORA, FLORA, ALYA, KHLOE, PIKA, ALITA, SONIA, EMMA, NADIA, ELLA 180, ELLA 340, ELLA 400, AVA, CARA

SIF-DV/90; id. 214650

- Double ø 90-siphon with connector
- Doppelsiphon ø 90 mit Anschluss
- Siphon double ø 90 avec raccordement

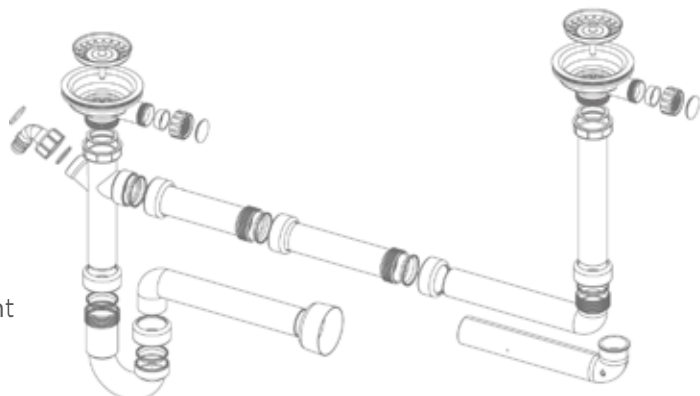

BINA, CARLA and all combinations of 2 kitchen sinks. Maximum distance between siphons is 550 mm.
BINA, CARLA und alle Kombinationen von 2 Spülbecken. Max. Abstand zwischen den Siphons 550 mm.
BINA, CARLA et toutes les combinaisons de 2 cuves de cuisine. La distance maximale entre les siphons est de 550 mm.

Universal siphons

Universal **Siphons** / **Siphons** universels

OUTFLOW VALVE; id. 015372

click-clack, fi 45, crome

AUSLAUFVENTIL

click-clack, fi 45, crom

VALVE D'ÉCOULEMENT

click-clack, fi 45, chrome

- for sinks with or without overflow
- für Spülbecken mit oder ohne Überfluss
- pour vasques avec ou sans trop-plein

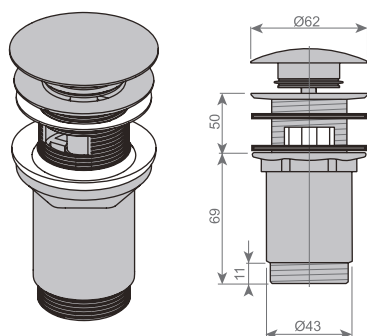

SILVIA, TINA, PETRA, TRU, SARA, BLANCA, LANA, EVA, MAJA, IVA, ANA, RONDO, META, KERI, JANA, BARBI, AJDA, BEA, BRINA, CHERI, KELI, LORA, ZENA 460, ZENA 600, OFELIA ON, OFELIA IN, OFELIA UN, ORIANA ON, ORIANA IN, ORIANA UN, OLIVIA ON, OLIVIA IN, OLIVIA UN, LINA, LUNA, HIGIEA, STERILIA

SIPHONE CROM; id. 015371

SIFON CROM / SIPHON CHROME

- for outflow valve click-clack, fi 45, chrome
- für Auslaufventil click-clack, fi 45, crom
- avec valve d'écoulement click-clack, fi 45, chrome

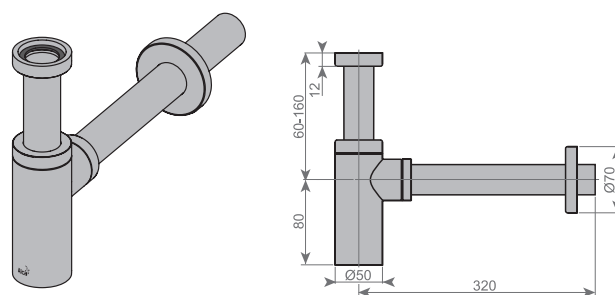

OVERFLOW SET **ÜBERFLUSS-SET** **SET TROP-PLEIN**

id. 015360

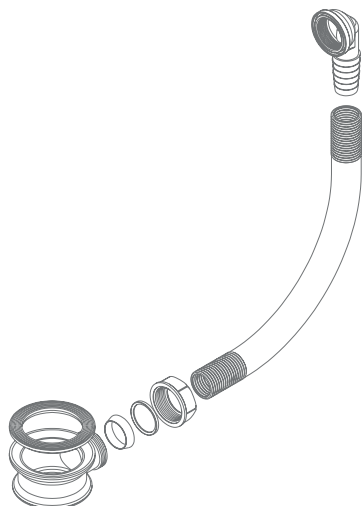

KERROCK COVER 108, FOR **KERROCK WASHBASINS** **KERROCK DECKEL 108, FÜR KERROCK** **WASCHBECKEN / COUVERCLE KERROCK** **108, POUR LES VASQUES KERROCK**

id. 596600

#Ø 93 mm

108

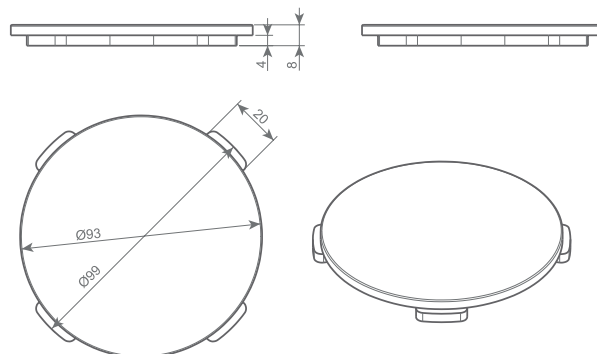

VITA, IRIS, ROSA, BRINA VARIANT, CHERI VARIANT, LORA VARIANT

EASE OF CARE.

It is for its simple cleaning and maintenance that Kerrock has become so popular; the stains can be removed by simply using water and ordinary cleaning agents.

For a silky shine and freshness of colours we recommend cleaning by using fine abrasives.



PFLEGELEICHT

Durch seine einfache Wartung und Reinigung ist Kerrock so beliebt: alle Flecken können einfach mit Wasser und gewöhnlichen Reinigungsmitteln entfernt werden.

Um den seidigen Glanz und Frische von Farben zu erhalten, empfehlen wir die Benutzung von feinen Schleifmitteln.

NETTOYAGE FACILE.

Kerrock est réputé pour son nettoyage et son entretien faciles. On élimine aisément les tâches avec de l'eau et des produits de nettoyage courants.

Pour conserver l'éclat soyeux et la fraîcheur des couleurs, nous recommandons un nettoyage avec des produits abrasifs fins.

KERIL, SPECIAL CREAMY ABRASIVE CLEANER

Special cleaner for Kerrock products, Kerrock surfaces and stainless steel.

KERIL, SPEZIAL CREME SCHEUERMILCH

Spezielles Putzmittel für Kerrock-Produkte, Kerrock-Flächen und rostfreien

KERIL, NETTOYANT ABRASIF CRÉMEUX SPECIAL

Nettoyant spécial pour les produits Kerrock, les surfaces en Kerrock et en acier inoxydable.

hygienic

Kerrock plus contains an antibacterial agent built into the overall structure of the material, which continuously eradicates bacteria and prevents their further development.

hygienisch

Kerrock plus beinhaltet ein in seine Struktur eingebautes antibakterielles Mittel, welches die Bakterien kontinuierlich beseitigt und ihre weitere Entwicklung verhindert.

Hygiénique

Kerrock plus contient un agent antibactérien. Ainsi lors du contact, il élimine définitivement les bactéries et empêche leur développement ultérieur.

maintenance

Kerrock is designed to allow easy cleaning. Infinite freshness and brilliance for your Kerrock product.

Wartung

Kerrock wurde entwickelt, um eine einfache Reinigung zu ermöglichen. Immer wieder Frische und Glanz für Ihr Kerrock-Produkt.

Entretien

Kerrock a été conçu pour un nettoyage facile. Une fraîcheur et un éclat infinis de votre produit en Kerrock.

restoration of surfaces

By grinding and polishing the surface can be fully restored.

Wiederherstellung der Oberflächen

Durch Schleifen und Polieren kann die Fläche vollständig wiederhergestellt werden.

Rénovation des surfaces

Les surfaces peuvent être entièrement restaurées par ponçage et polissage.





Why a Kerrock washbasin?

Weshalb Kerrock Waschbecken?

Pourquoi choisir un lavabo Kerrock ?

- Because it is pleasant to the touch and non-porous. /
Angenehm auf Berührung und porenfrei. / Parce qu'il
est agréable au toucher et non poreux.
- Because it is environmentally friendly. /
Umweltfreundlich. / Parce qu'il est respectueux de
l'environnement.
- Because it is resistant to both mechanical impact and
chemicals. / Chemisch und mechanisch beständig. /
Parce qu'il est résistant aux produits chimiques et aux
chocs.
- Because of its styling. / Ästhetisch. / Parce qu'il est
esthétique.
- Because it is versatile, flexible in design. / Überaus
vielseitig und anpassungsfähig. / Parce qu'il est
polyvalent & flexible.
- Because it offers the option of thermoforming. /
Warmumformung möglich. / Parce qu'il est adapté au
thermoformage.

EASE OF CARE

PFLEGELEICHT / NETTOYAGE FACILE



- simple to clean and maintain / einfache
Reinigung und Wartung / nettoyage et
entretien faciles
- ordinary agents / gewöhnliche Putzmittel /
produits de nettoyage conventionnels
- fine abrasives / feine Schleifmittel / produits
abrasifs fins
- grinding and polishing / Schleifen und Polieren
/ ponçage et polissage

MAIN ADVANTAGES FOR
YOUR BUSINESS

GESCHÄFTSVORTEILE

AVANTAGES
PROFESSIONNELS

Whatever your idea

WAS



Live your life.

In colours!

LEBEN SIE IHR LEBEN. IN FARBEN!

RAYONNEZ. EN COULEURS !



Kerrock business flexibility
Kerrock Geschäftsflexibilität
Kerrock flexibilité professionnelle



Kerrock consulting
Kerrock Beratung
Kerrock consultation



Kerrock technical support
Kerrock technische Unterstützung
Kerrock support technique



Kerrock training
Kerrock Ausbildung
Kerrock formation



Kerrock, made in Europe
Kerrock, hergestellt in Europa
Kerrock, fabriqué en Europe

TRI-VARIO SERIES

An innovative system that uses different variations of washbasins and their installation to provide highly flexible bathroom design.

Dieses innovative System ermöglicht mit verschiedenen Waschbecken-variationen und Einbaumöglichkeiten, außerordentliche Flexibilität bei eine Badentwurf.

Un système innovant qui vous permet d'obtenir un maximum de flexibilité dans la conception de votre salle de bains grâce aux différentes variantes de vasques et à leur installation.

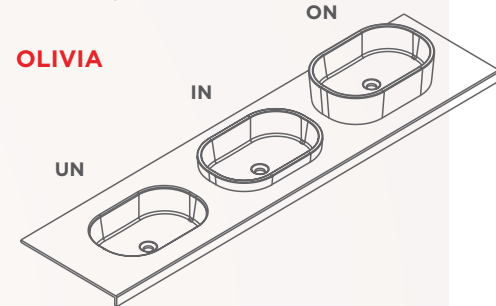
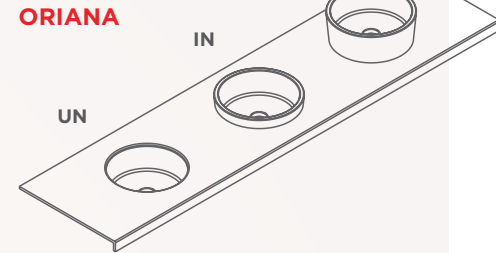
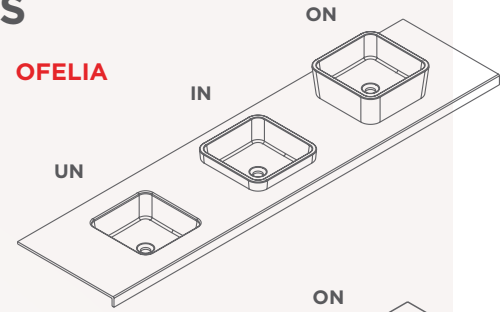

a. We deliver. WASHBASINS AND SINKS.

Was auch immer Ihre Idee ist. Wir liefern.
WASCH- UND SPÜLBECKEN.

Quelle que soit votre idée. Nous la réalisons.
VASQUES ET CUVES.



Kerrock manufacturing –
The NEW dimension of flexibility.

Kerrock Produktion – NEUE Dimension der Flexibilität

Fabrication Kerrock – NOUVELLES dimension de la flexibilité

Extreme flexibility during the Kerrock manufacturing process is enabled by using the innovative technological processes. We never fail to find a response to your challenges.

Innovative technologische Prozesse bei Kerrock-Produktion ermöglichen uns außerordentliche Anpassungsfähigkeit. Für Ihre Herausforderung haben wir deshalb stets eine Antwort parat.

Les procédés technologiques innovants utilisés pour la fabrication de Kerrock nous permettent une flexibilité extrême. Nous trouvons donc toujours une réponse à votre défi.

kerrock[®]
by KOLPA



Kolpa d.d.
Rosalnice 5

SI 8330 Metlika, Slovenia / Slowenien / Slovénie

Phone: / Tel.: / Tél. : + 386 7 36 92 100

Fax: + 386 7 36 92 166

www.kolpa.si

SALES: / VERTRIEB: / VENTE :

Pod Barončevim hribom 4

SI 8000 Novo mesto, Slovenia / Slowenien / Slovénie

Phone: / Tel.: / Tél. : + 386 7 393 33 00

Fax: + 386 7 393 33 50

E-mail: / E-Mail: / Courriel : info@kolpa.si



www.kerrock.eu

kerrock[®]
by KOLPA